

Meistergram[®]
THE PERSONALIZATION PEOPLE™

M800 SERIES

USER MANUAL

**XLC PARTS
IDENTIFICATION**

From the library of: Diamond Needle Corp

FRAME ASSEMBLY: VIEW 1

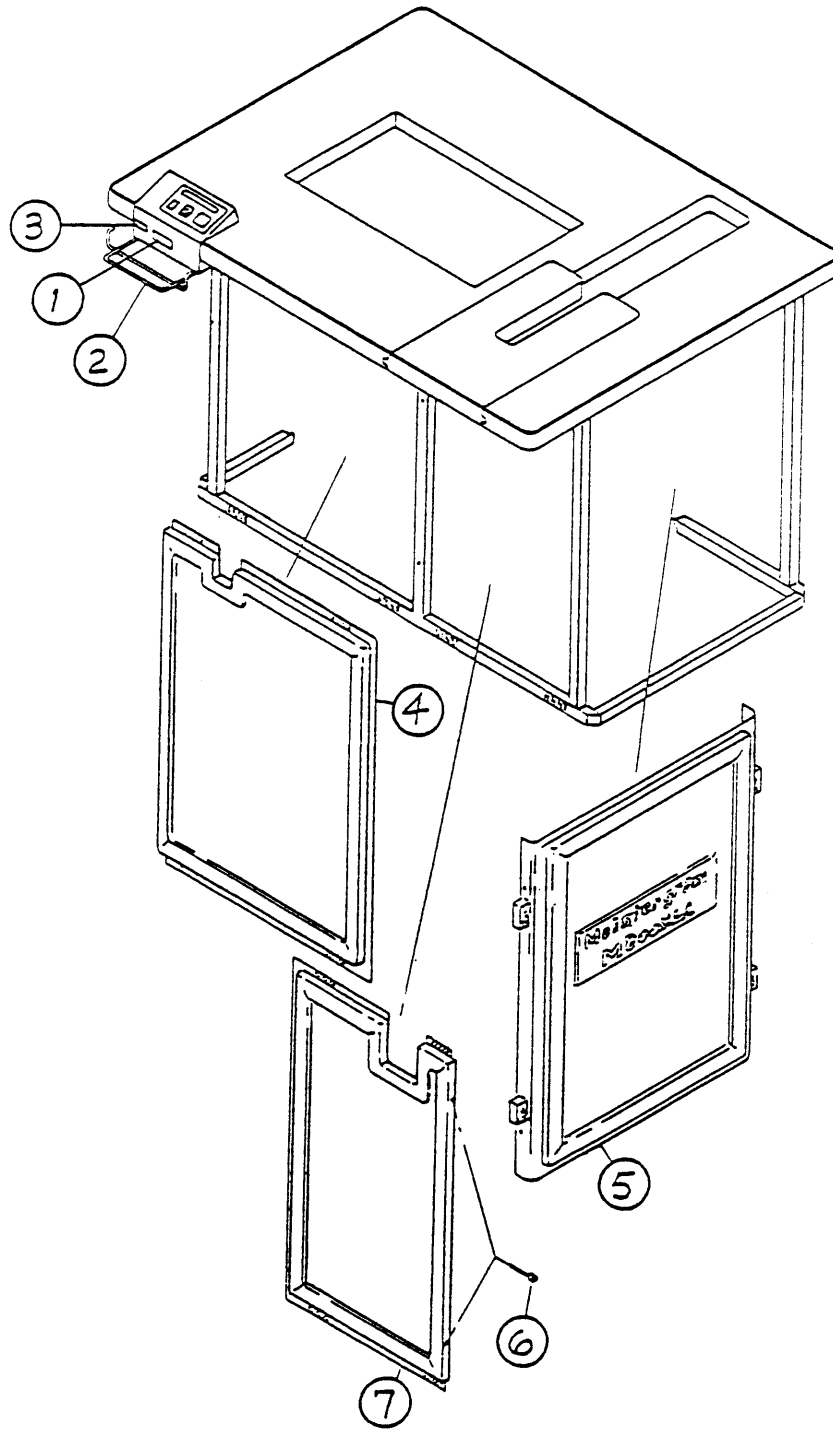

From the library of: Diamond Needle Corp

FRAME ASSEMBLY: VIEW 1

<u>Item</u>	<u>Qty</u>	<u>Part No.</u>	<u>Description</u>
1	1	P896012	Motor Switch Label
2	1	P670010	Keyboard Rack, M800/XLM
3	1	P896010	Console Power Label
4	1	P670004	Panel, Left Front, XLM
5	2	P673008	XLC Side Panel
6	12	P670083	#6 X 1/2 Type AB Phillips Decorative Head Screw
7	1	P673005	XLC Right Front Panel

FRAME ASSEMBLY: VIEW 2

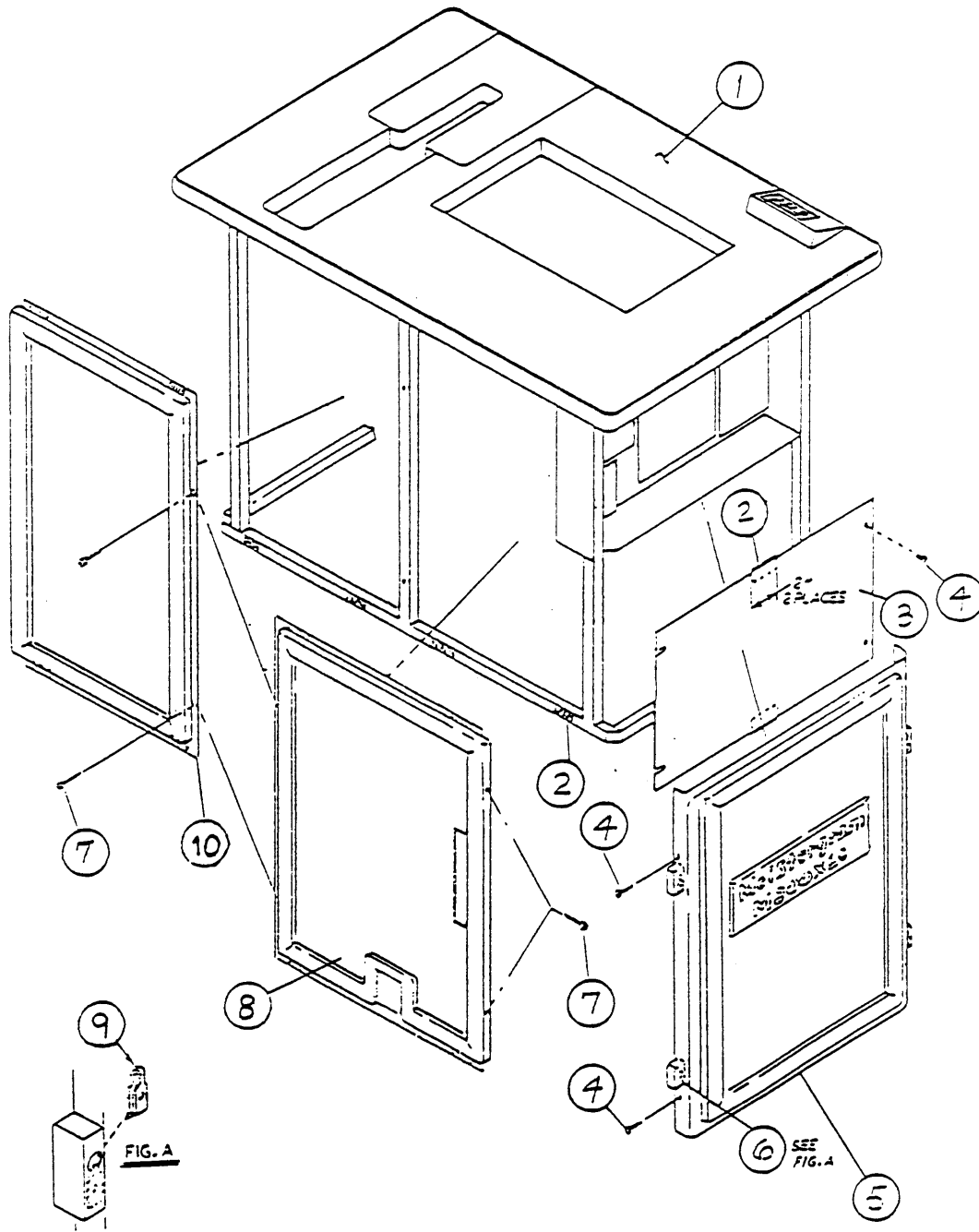

From the library of: Diamond Needle Corp

FRAME ASSEMBLY: VIEW 2

<u>Item</u>	<u>Qty</u>	<u>Part No.</u>	<u>Description</u>
1	1	ZP673900	M800XLC Table Assembly
2	3.5'	9P520007	Adhesive Back Loop Fastening-Bulk
3	1	P670835	Cover, Plate, Electronics Enclosure
4	12	P840203	8-32 X 1/2 Hex Head Self-Tapping Screw
5	2	P673008	XLC Side Panel
6	8	P620011	Tinnerman Clip
7	12	P670083	#6 X 1/2 Type AB Phillips Decorative Head Screw
8	1	P670006	Panel Left Rear, XLM
9	8	P620011	Tinnerman Clip
10	1	P670007	Panel Right Rear, XLM

FRAME ASSEMBLY: VIEW 3

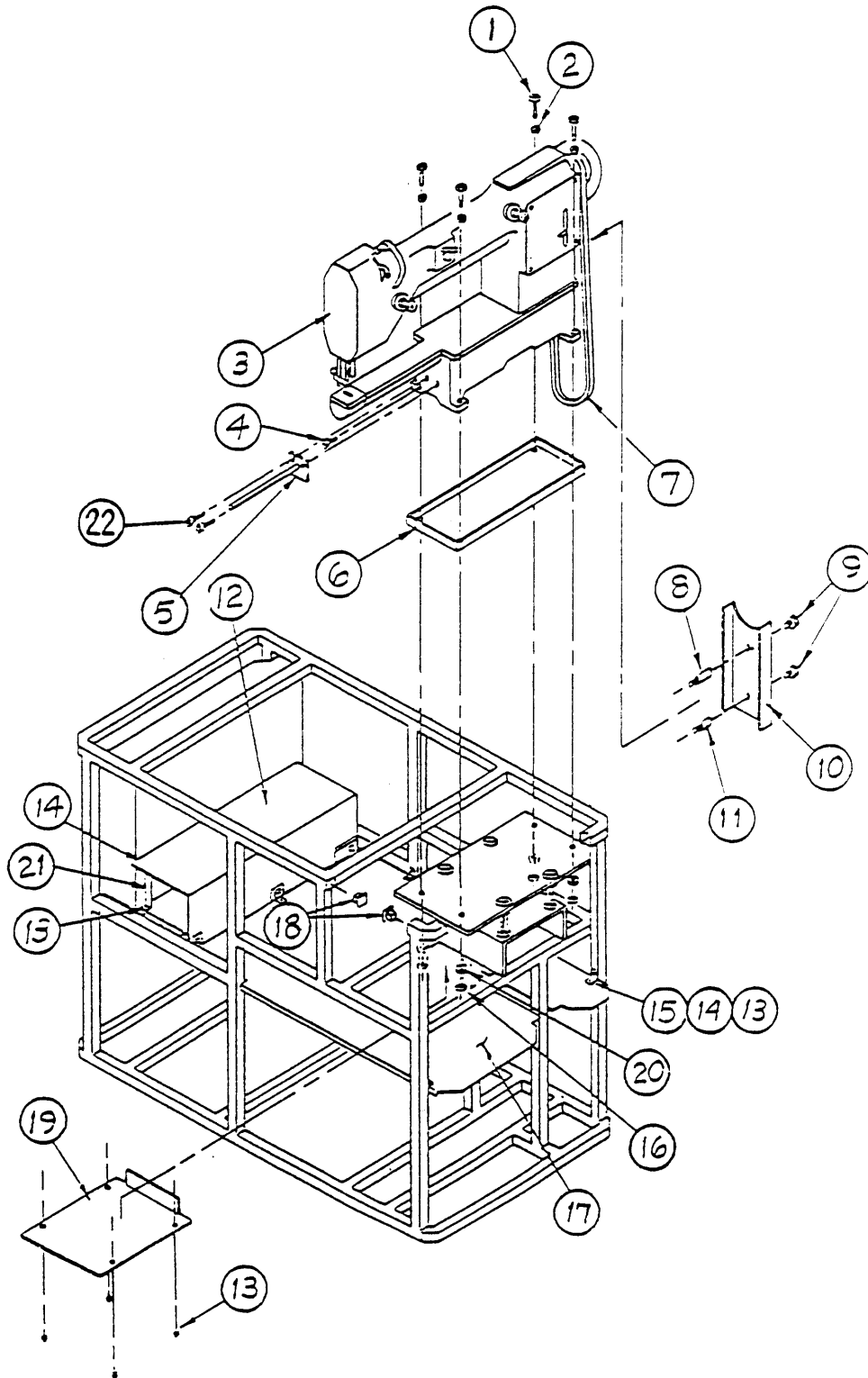

From the library of: Diamond Needle Corp

FRAME ASSEMBLY: VIEW 3

Item	Qty	Part No.	Description
1	4	P840604	5/16-18x1-1/2" Hex Head Bolt
2	8	P840582	5/16 Split Lock Washer
3	1	ZP661000	M800XLC Head Assembly
4	1	P840188	6-32x1/2 Pan Head Screw
5	1	P661262	Pivot Shaft
6	1	P673842	M800XLC Oil Drip Pan
7	1	P820051	V-belt 51"
8	1	P661265	Spacer/5/16-18/1.19lg/.438 Dia M/F
9	2	P840078	5/16-18 X 3/8 Socket Headcap Screw
10	1	P661261	XLC Belt Guard
11	1	P661266	Standoff,5/16-18/.88lg/.438dia M/F
12	1	P671850	Cover, Transformer XLM (ETL)
13	29	P840203	8-32 X 1/2 Hex Head Self-Tapping Screw
14	12	P840627	3/16x1/8 Pop Rivet-Al/Al Mandrel
15	10	P671841	M800XLC Partition Plate Bracket
16	4	P840707	5/16-18 Hex Nut
17	1	P673841	Partition Plate
18	2	P673811	Cap, Frame Tube
19	1	P673843	XLC Catch Plate
20	8	P840561	5/16 Flat Washer
21	2	P671851	Transformer, Cover Bracket
22	2	P840001	M6x20 Socket Head Cap Screw

FRAME ASSEMBLY: VIEW 4

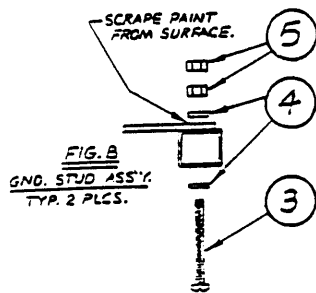
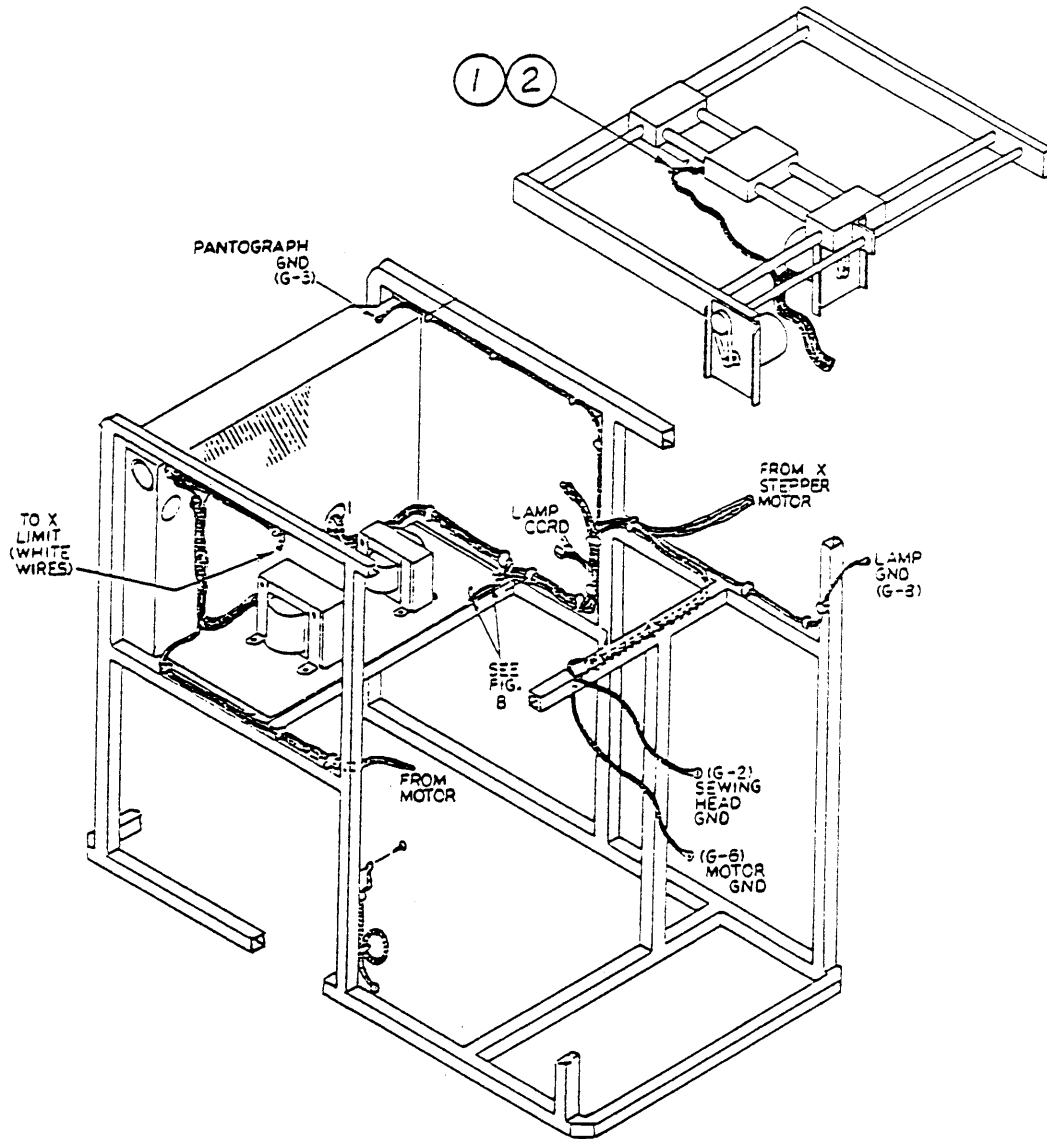

From the library of: Diamond Needle Corp

FRAME ASSEMBLY: VIEW 4

Item	Qty	Part No.	Description
1	25	P312027	5" Cable Tie
2	1	P620105	16N1018 Spacer
3	3	P840432	10-32 X 2" Phillips Head Screw
4	4	P840535	#10 Flat Washer (brass)
5	4	P840742	#10-32 Hex Nut Brass

FRAME ASSEMBLY: VIEW 5

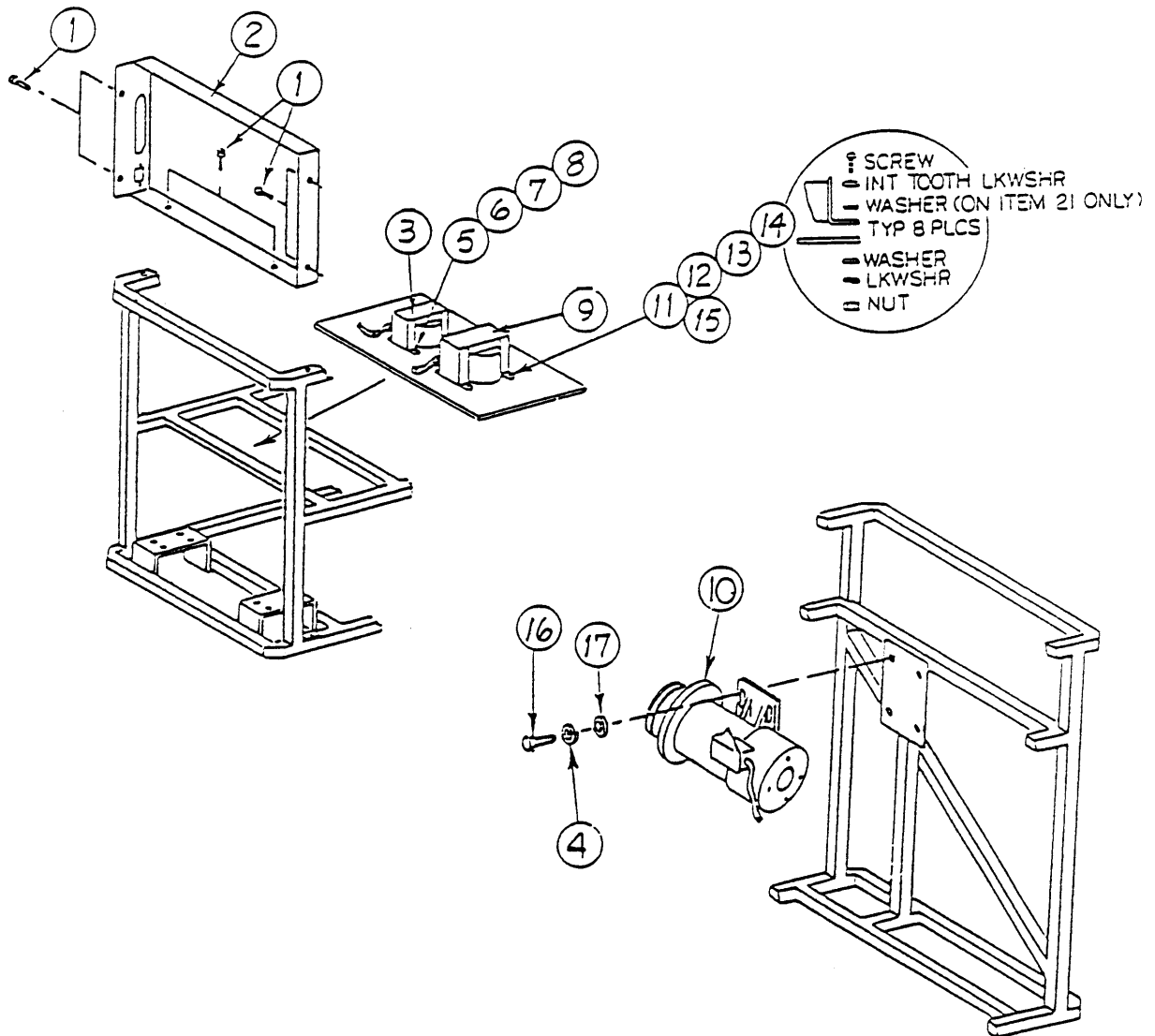

From the library of: Diamond Needle Corp

FRAME ASSEMBLY: VIEW 5

Item	Qty	Part No.	Description
1	29	P840203	8-32 X 1/2 Hex Head Self-Tapping Screw
2	1	P670830	Electronics Enclosure, M800/XLM
3	1	P680850	Transformer, M800/XLM Control
4	8	P840582	5/16 Split Lock Washer
5	4	P840156	#8-32x1/2" Hex Head Machine Screw
6	4	P840520	#8 Flat Washer
7	4	P840523	#8 Lockwasher, Split
8	4	P840730	8-32 Hex Nut
9	1	P680855	Transformer, M800/XLM Isolation
10	1	ZP680600	DC Motor Assembly XLM
11	4	P840430	#10-32 X 1/2 Pan Head Screw
12	6	P840530	#10 Flat Washer
13	6	P840572	#10 Lock Washer Split
14	4	P840740	10-32 Hex Nut
15	4	P840506	#10 Internal Tooth Lock Washer
16	4	P840603	5/16-18x1" Hex Head Bolt
17	8	P840561	5/16 Flat Washer

FRAME ASSEMBLY: VIEW 6

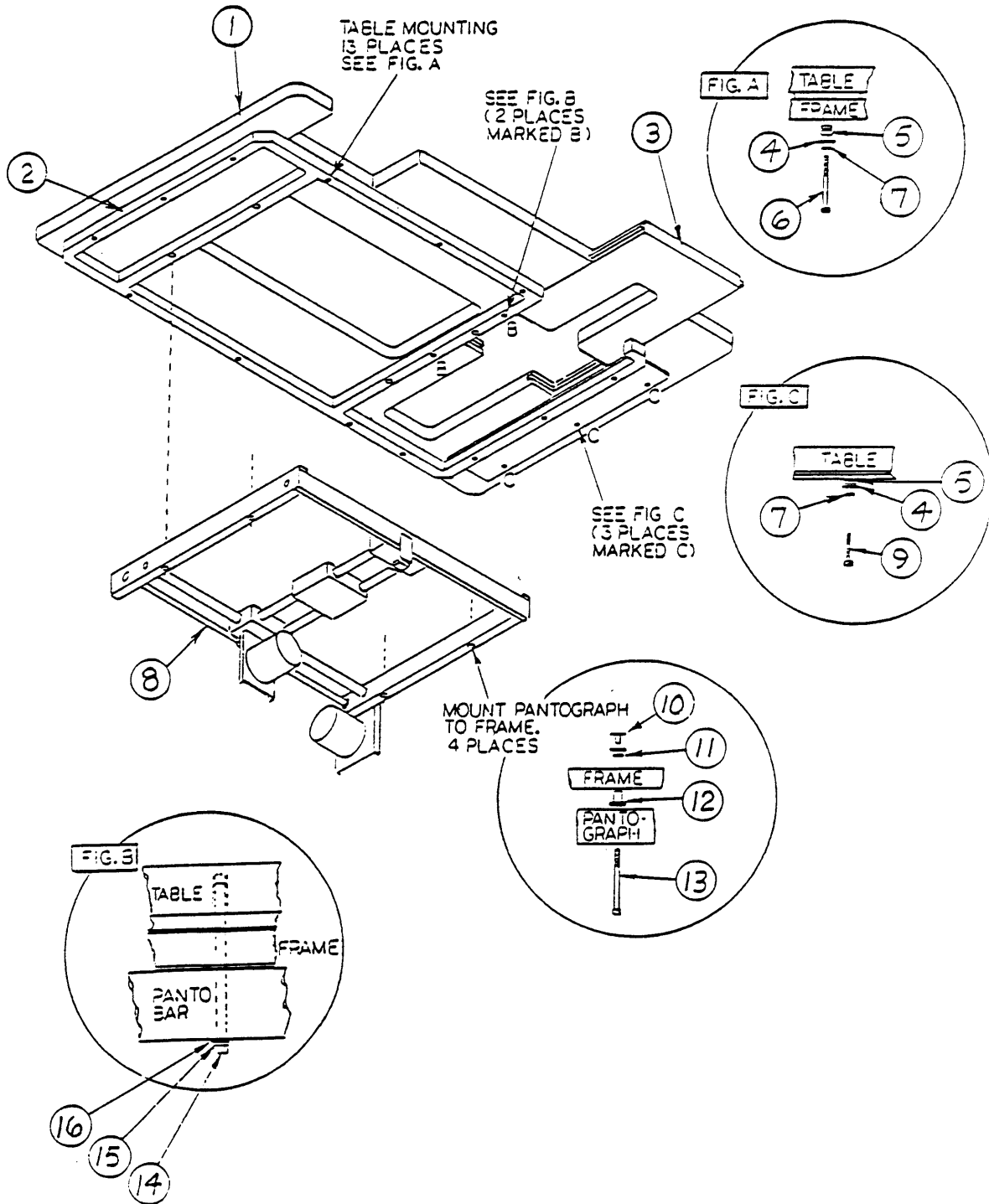

From the library of: Diamond Needle Corp

FRAME ASSEMBLY: VIEW 6

Item	Qty	Part No.	Description
1	1	P673820	M800XLC Table Top
2	1	P673810	M800XLC Frame
3	1	P673821	M800XLC Table Insert
4	24	P840540	1/4" SAE Flat Washer-Plated
5	16	P840915	Rubber Grommet Z-399
6	13	P840057	1/4-20x2-1/4" Socket Head Screw
7	24	P840580	1/4" Lock Washer
8	1	ZP670400	Pantograph Assembly XLM
9	3	P840056	1/4-20 X1 1/4 Sock Head Screw
10	4	P520406	1/4-20 X 7/16 T-Nut Plain Base
11	4	P520408	Grommet - M700 Pantograph
12	4	P520509	Molly Well - Nut
13	4	P840062	1/4x20 X 3" Socket Head Cap Screw
14	2	P840436	10-32 X 3 3/4" Socket Head Cap Screw
15	6	P840572	#10 Lock Washer Split
16	6	P840530	#10 Flat Washer

FRAME ASSEMBLY: VIEW 7

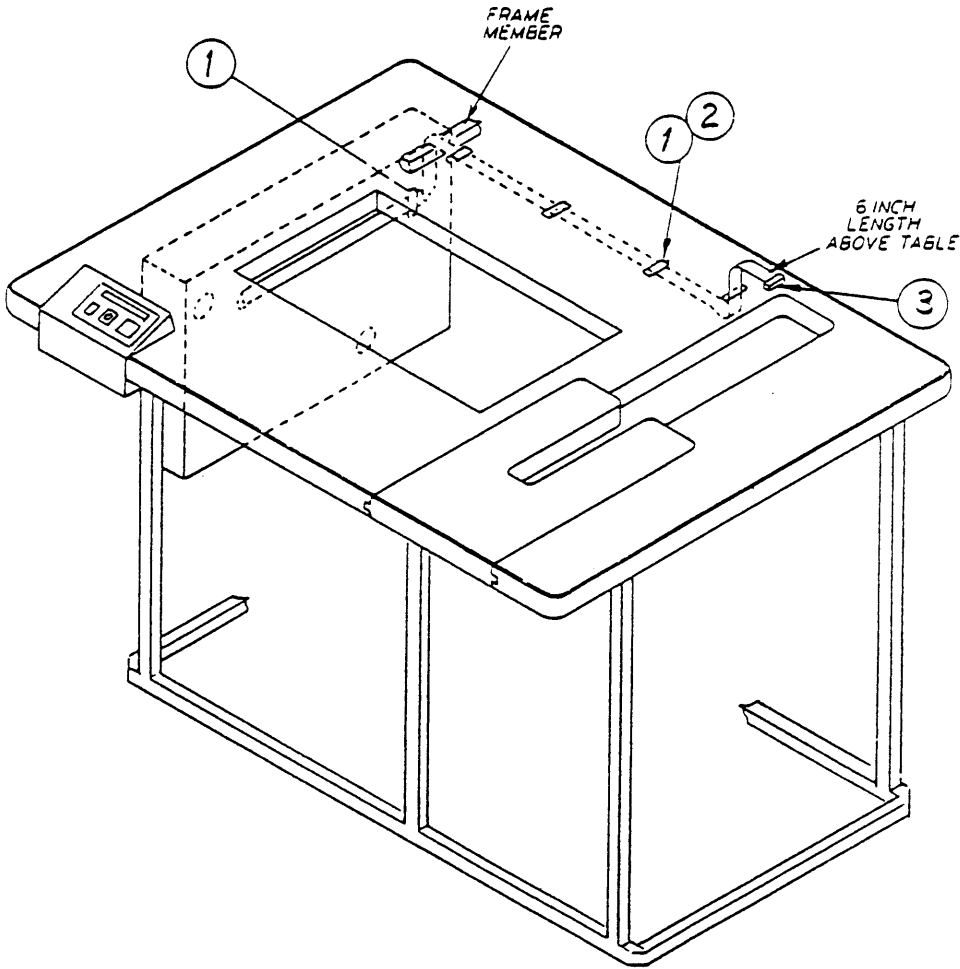

From the library of: Diamond Needle Corp

FRAME ASSEMBLY: VIEW 7

Item	Qty	Part No.	Description
1	4	P520109	Flat Cable Mount
2	3	P840347	#6 X 1/2 Wood Screw
3	1	P683745	Head Interface Cable, XLC

FRAME ASSEMBLY: VIEW 8

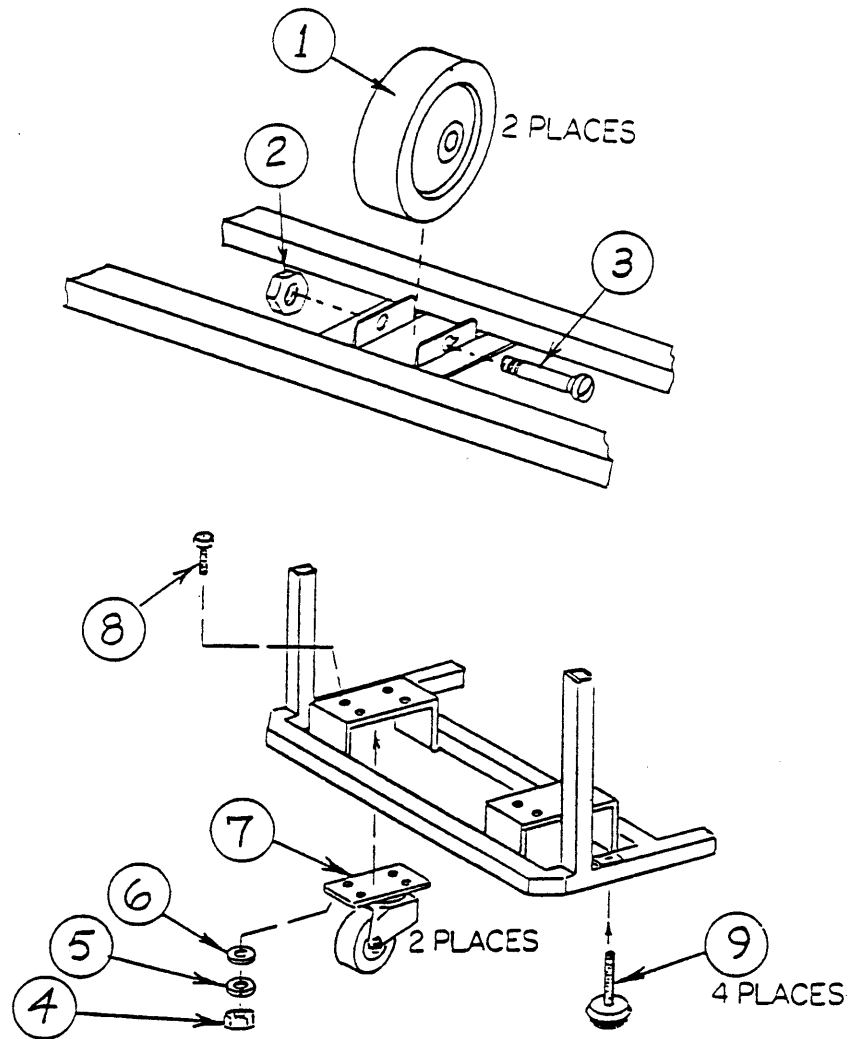

From the library of: Diamond Needle Corp

FRAME ASSEMBLY: VIEW 8

<u>Item</u>	<u>Qty</u>	<u>Part No.</u>	<u>Description</u>
1	2	P670804	Wheel 4" Diameter
2	2	P520064	Locknut, Wheel
3	2	P520066	Axle, Wheel
4	8	P840710	1/4-20 Hex Nut
5	8	P840580	1/4" Lock Washer
6	8	P840540	1/4" SAE Flat Washer-Plated
7	2	P670801	Caster
8	8	P840622	Bolt, 1/4-20x5/8 Hex Head
9	4	P670802	Leveling Foot, M800/XLM

FRAME ASSEMBLY: VIEW 9

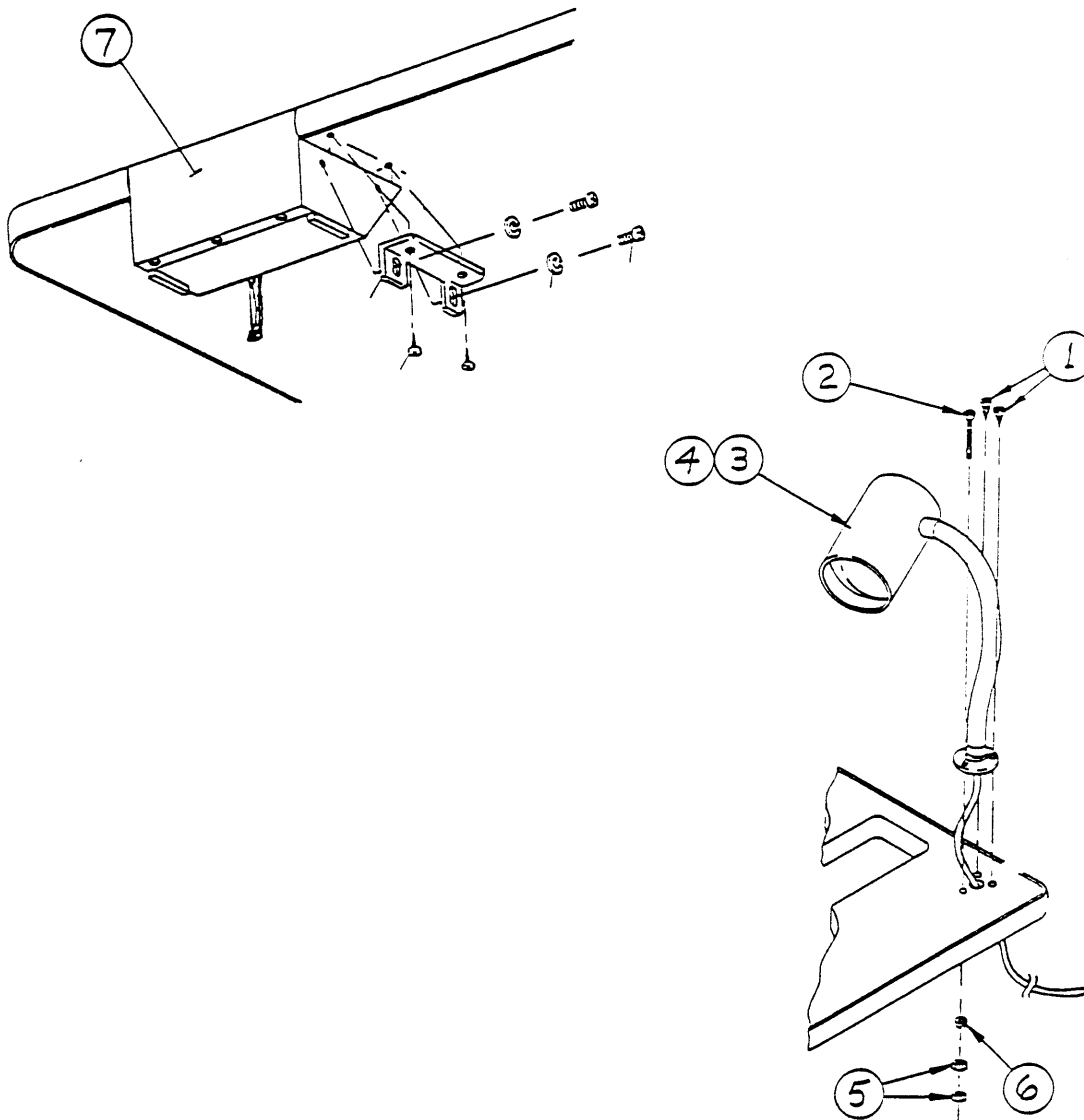

From the library of: Diamond Needle Corp

FRAME ASSEMBLY: VIEW 9

<u>Item</u>	<u>Qty</u>	<u>Part No.</u>	<u>Description</u>
1	2	P840313	#10 X 3/4" Phillips Round Head Screw
2	3	P840432	10-32 X 2" Phillips Head Screw
3	1	P820037	60 Watt Light Bulb, rugged duty
4	1	P420022	Lamp, 84" Cord/flange Mount
5	2	P840740	10-32 Hex Nut
6	1	P840572	#10 Lock Washer Split
7	1	ZP683500	M800XLC Console Assembly

FRAME ASSEMBLY/TABLE TOP

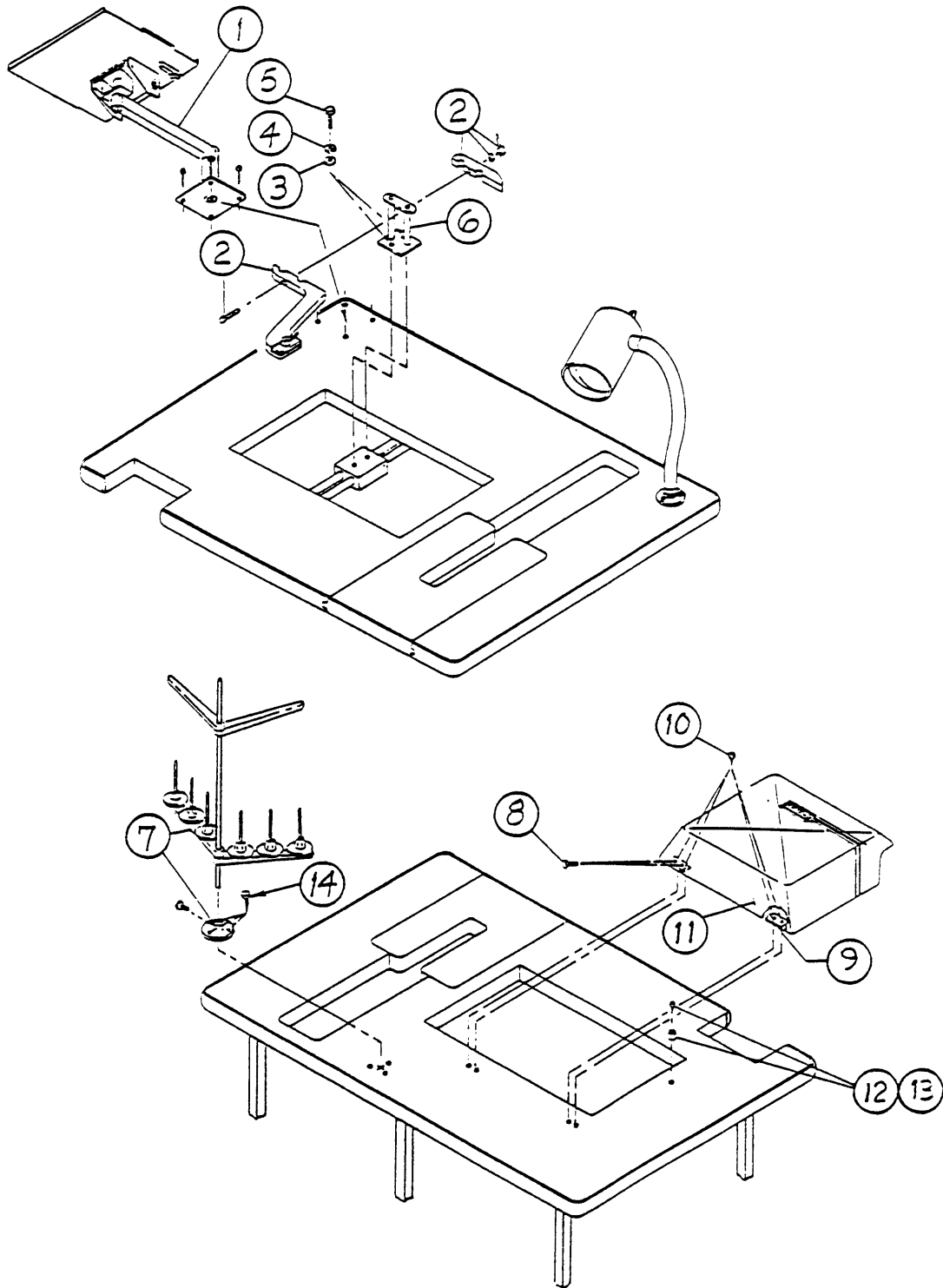

From the library of: Diamond Needle Corp

FRAME ASSEMBLY/TABLE TOP

Item	Qty	Part No.	Description
1	1	ZP670100	CRT Arm Assembly XLM
2	1	ZP683500	M800XLC Console Assembly
3	2	P840561	5/16 Flat Washer
4	2	P840582	5/16 Split Lock Washer
5	2	P840601	5/16-18 X 3/4" Hex Head Bolt
6	1	P673501	XLC Hoop Arm Base
7	1	P673030	Thread Stand, 6 Cone
8	4	P840627	3/16x1/8 Pop Rivet- Al/Al Mand.
9	2	P520011	Pantograph Cover Hinge
10	8	P840305	#7 X 3/4 Round Head Wood Screw Black
11	1	P670915	Panto Cover, M800XLM
12	1	P840905	Rubber Stop 3/8x1/4 ZB1087
13	1	P840302	#4 X 3/8" Wood Screw
14	3	P840313	#10 X 3/4" Phillips Round Head Screw

CONTROL CONSOLE ASSEMBLY: VIEW 1

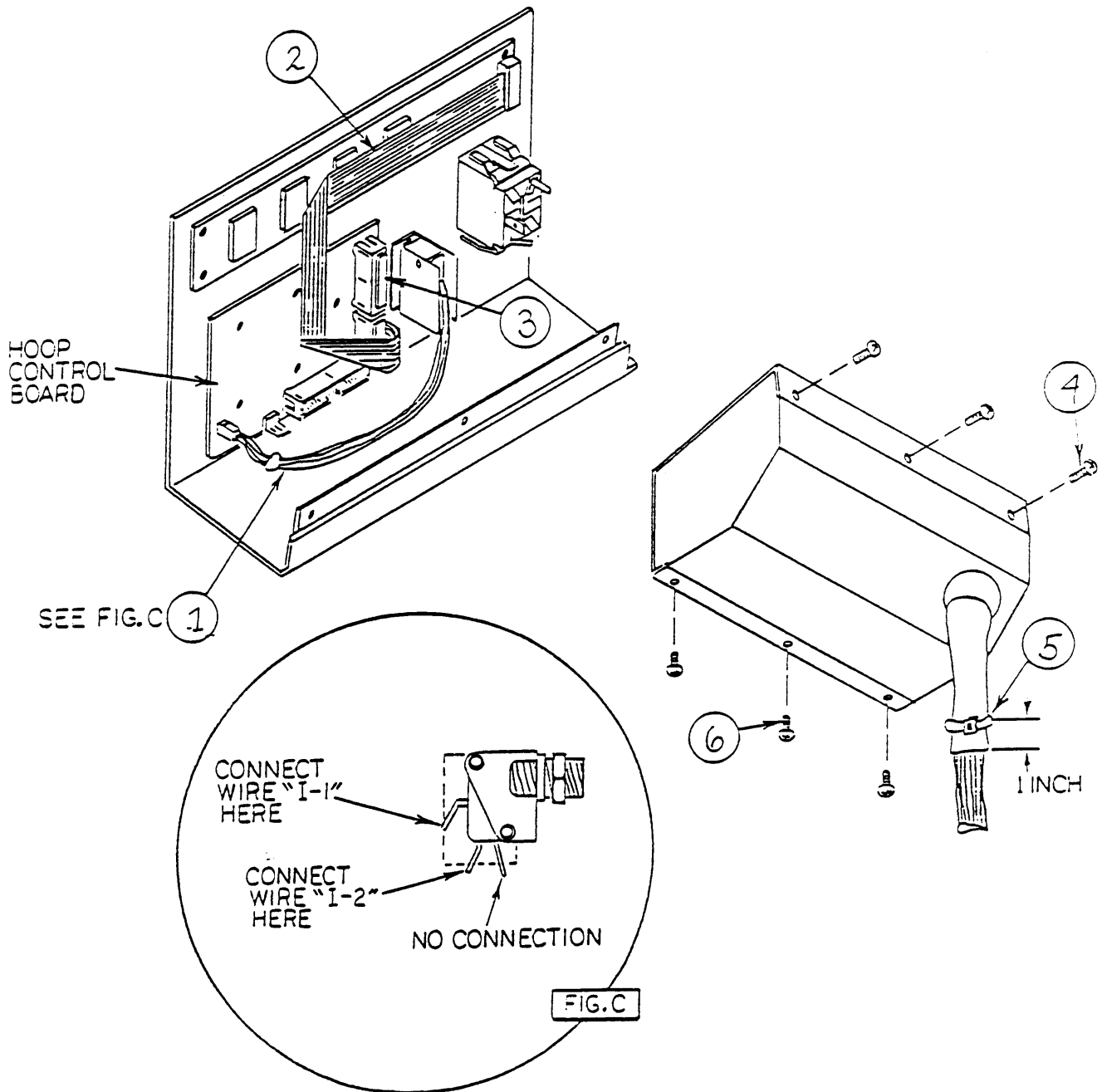

From the library of: Diamond Needle Corp

CONTROL CONSOLE ASSEMBLY: VIEW 1

<u>Item</u>	<u>Qty</u>	<u>Part No.</u>	<u>Description</u>
1	1	P680716	Harness, Emergency Stop Switch
2	1	ZP680550	LCD/Ribbon Complete
3	1	P680728	Tape Drive Jumper Block
4	6	P840453	8-32 X 1/4 Phillips Truss Head- Black Oxide
5	2	P312027	5" Cable Tie
6	6	P840453	8-32 X 1/4 Phillips Truss Head- Black Oxide

CONTROL CONSOLE ASSEMBLY: VIEW 2

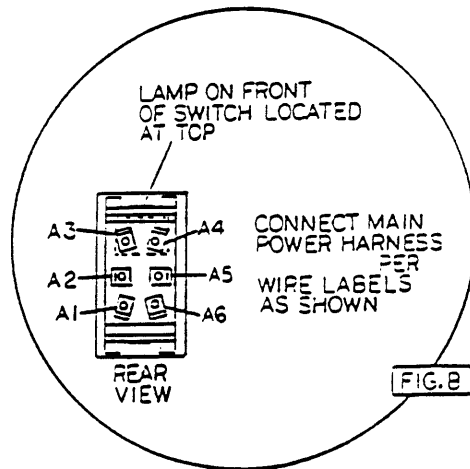
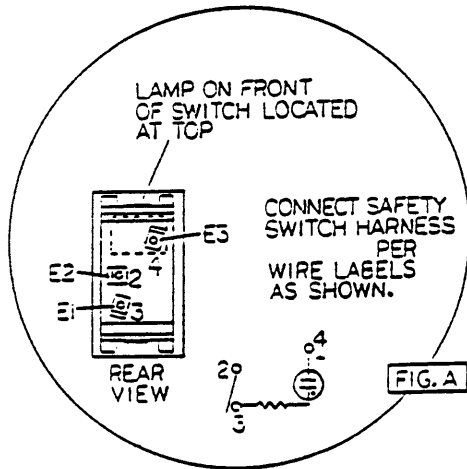
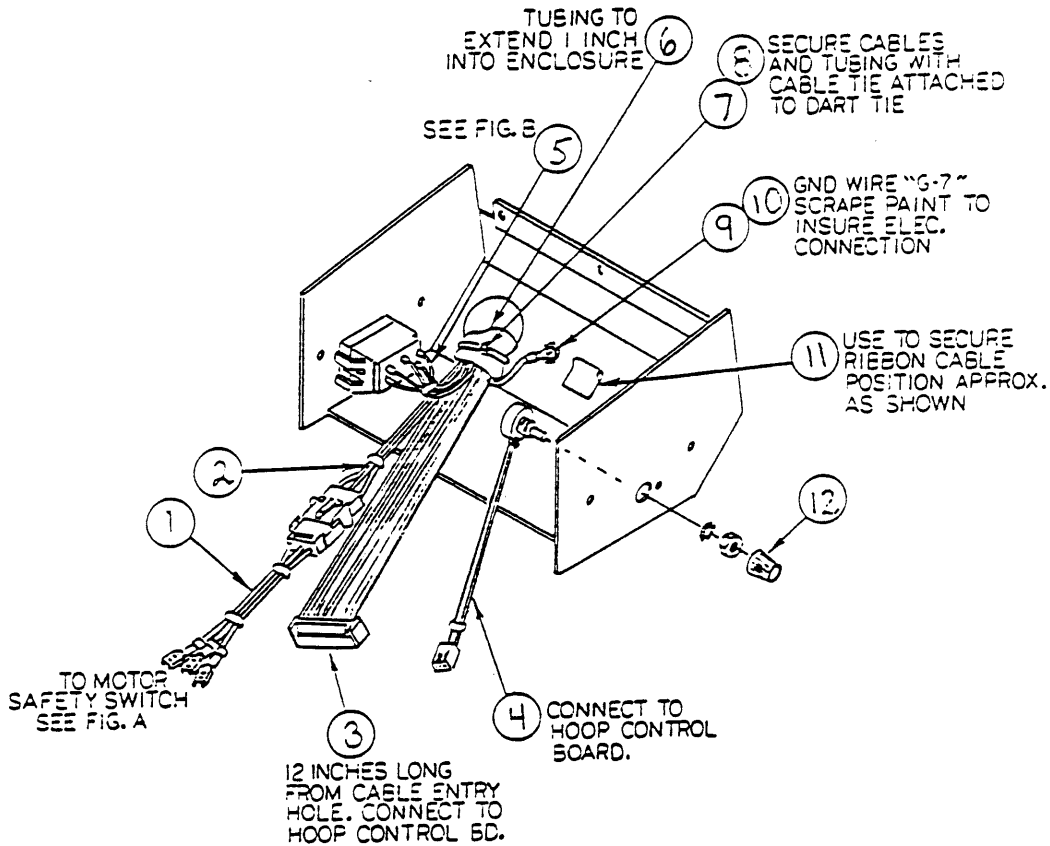

From the library of: Diamond Needle Corp

CONTROL CONSOLE ASSEMBLY: VIEW 2

Item	Qty	Part No.	Description
1	1	P680711	Harness, Console Safety Switch
2	1	P680710	XLM D.C. Drive Safety Harness
3	1	P680730	XLM Console/SBC Cable
4	1	P680717	Harness, View Adjust
5	1	P680750	XLM Power Switch Harness
6	5"	9P680515	Zipper Tubing 1" #ZIP 31-1
7	2	P312027	5" Cable Tie
8	1	P530237	Dart Cable Ties
9	1	P840150	6-32-1/4 Rd Head Phillips
10	1	P680714	XLM Console Ground Wire
11	1	P520085	Flat Wire Clip, Adhesive Backed
12	1	P680530	Plastic Knob

CONTROL CONSOLE ASSEMBLY: VIEW 3

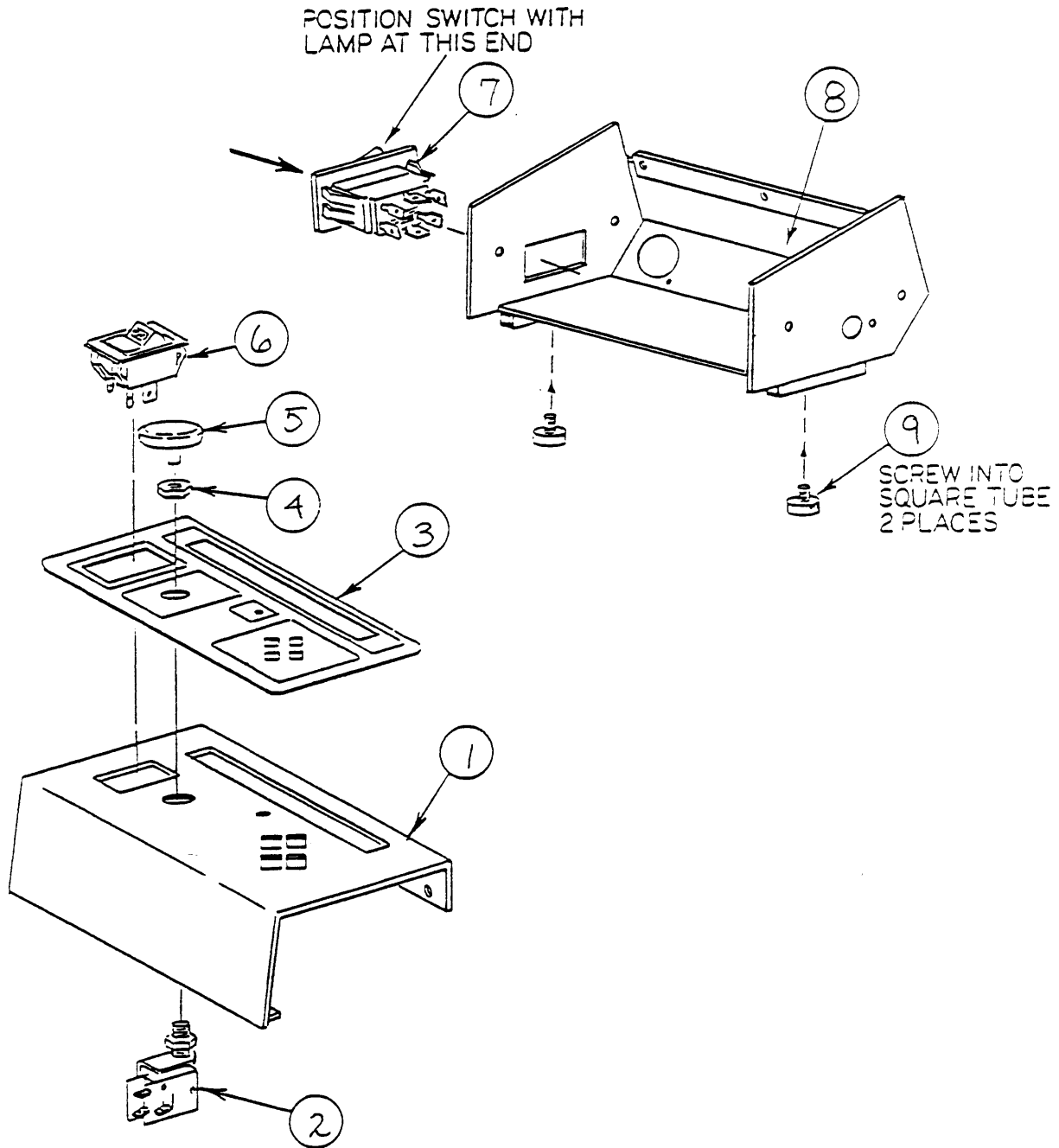

From the library of: Diamond Needle Corp

CONTROL CONSOLE ASSEMBLY: VIEW 3

Item	Qty	Part No.	Description
1	1	P683501	M800XLC Console Panel
2	1	P520018	Stop Switch
3	1	P896021	XLC Console Decal
4	1	P520019	Stop Switch Locknut #2526
5	1	P520020	Red Button, Stop Switch
6	1	P683505	M800XLC Motor Power Switch
7	1	P520012	Illuminated Power Switch
8	1	P683502	M800XLC Console Enclosure
9	2	P220501	Template Holder Thumbscrew

CONTROL CONSOLE ASSEMBLY: VIEW 4

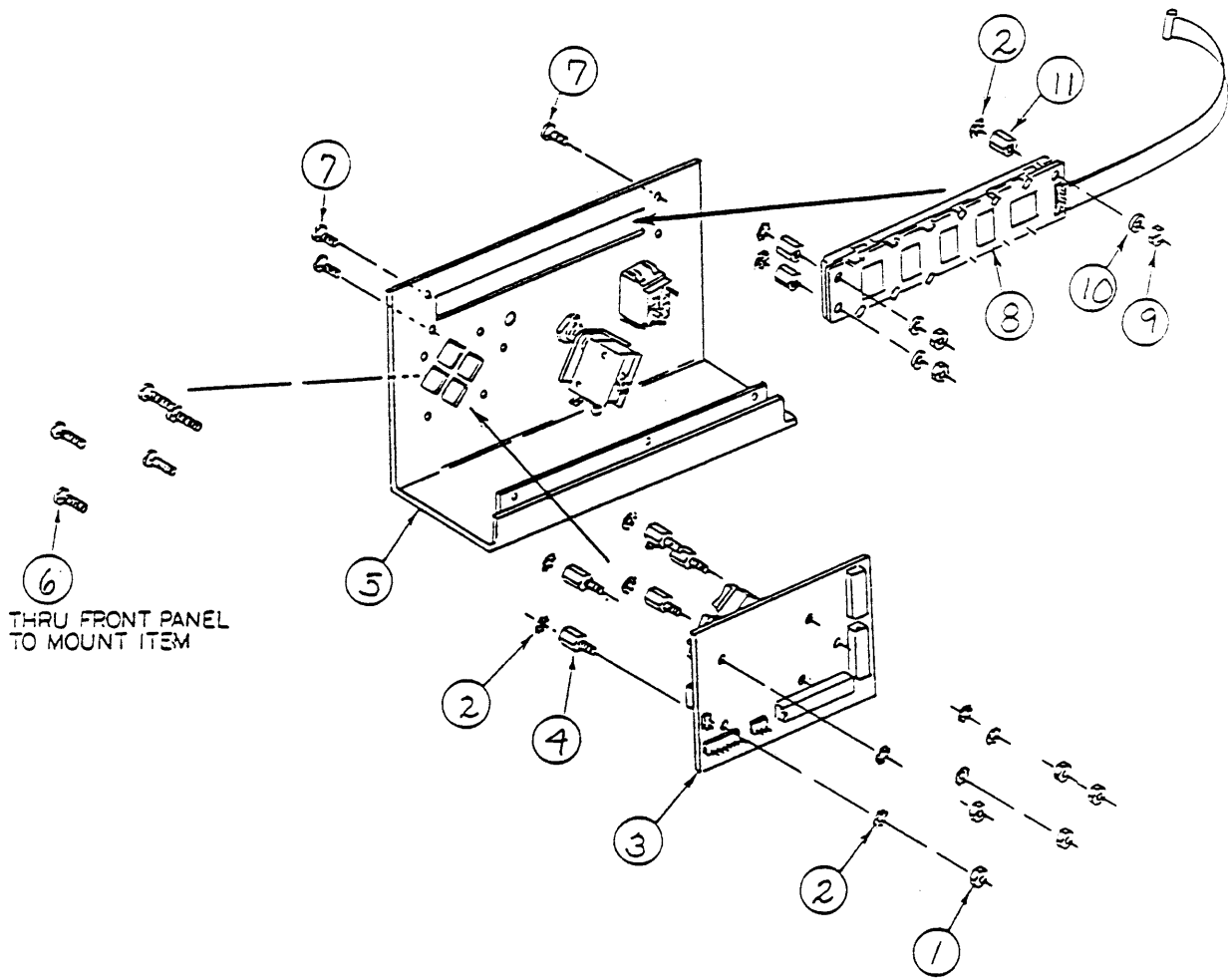

From the library of: Diamond Needle Corp

CONTROL CONSOLE ASSEMBLY: VIEW 4

Item	Qty	Part No.	Description
1	5	P840715	#4-40 Hex Nut
2	13	P840502	#4 External Tooth, Washer
3	1	P680510	Hoop Control Board M800/XL
4	2	P680511	4-40 X 7/16" Long Hex Standoff M/F
5	1	P683501	M800XLC Console Panel
6	5	P840390	4-40 x 3/8 Slotted Flat Head Machine Screw
7	3	P840402	Screw, #4-40 X 5/8 Slotted Flat Head
8	1	ZP680550	LCD/Ribbon Complete
9	3	P840716	4-40 Small Pattern Hex Nut
10	3	P840512	Nylon Washer, #4
11	3	P680514	4-40 X 1/4 Lg Hex Standoff, Nylon

FRAME ASSEMBLY/ELECTRONICS ENCLOSURE

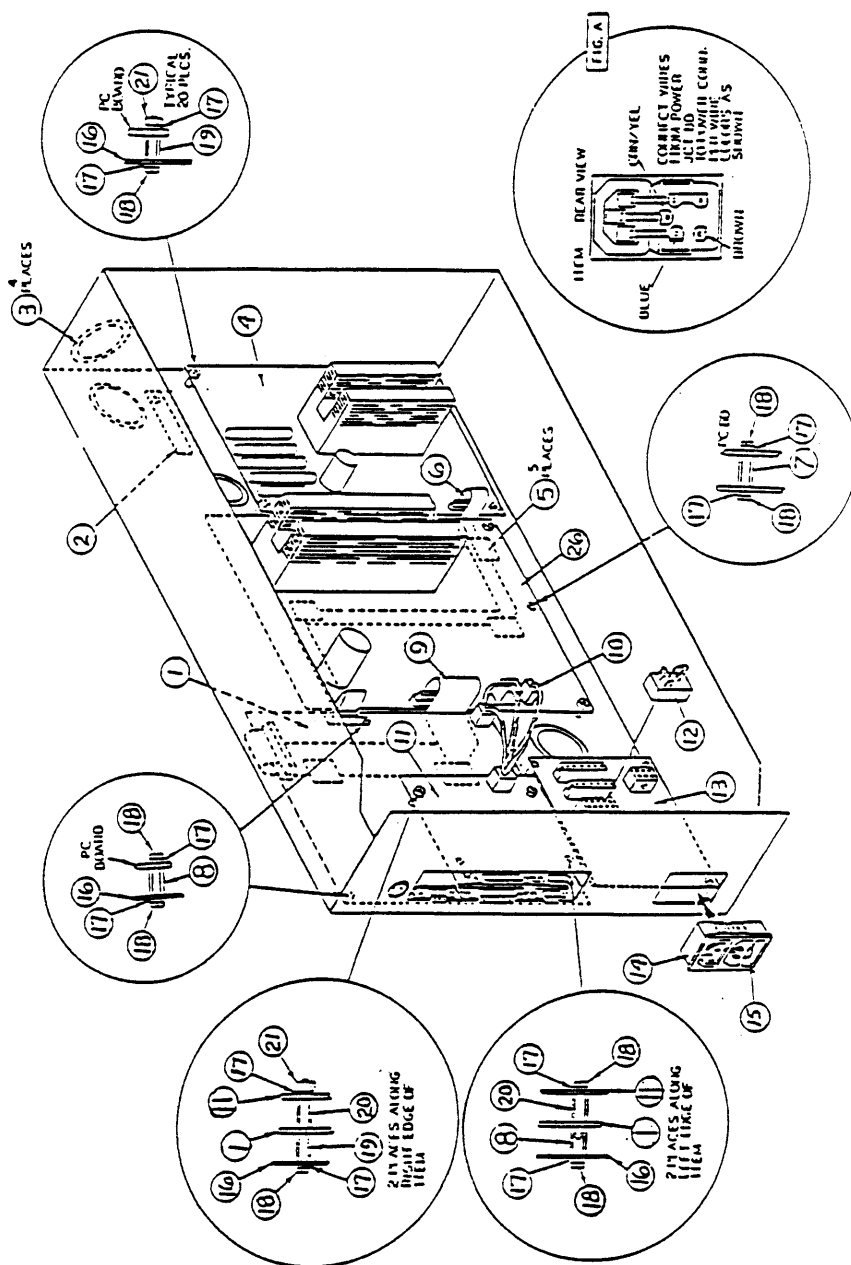

From the library of: Diamond Needle Corp

FRAME ASSEMBLY/ELECTRONICS ENCLOSURE

Item	Qty	Part No.	Description
1	1	ZP680110	Single Board Computer With Video
2	1	P896011	Wire Clearance Label
3	2ft	9P530200	Grommet Strip (Power Electronics Encl)
4	1	P680300	DC Drive Control Card, M800/XLM
5	5	P520085	Flat Wire Clip, Adhesive Backed
6	1	P680720	Ribbon Cable, DC Drive To SBC
7	1	P680724	Nylon Standoff, 6/32 X 1/2 Full Thread
8	4	P530132	Standoff #6-32 x 1/2" Internal Thread
9	1	P680725	Ribbon Cable, SBC To CE
10	1	P680758	Harness, Floppy Control Power
11	1	P680125	Floppy Controller Board
12	1	P680722	Jumper Block, 110Volt, Power Junction Board
13	1	P680400	Power Junction Board, M800/XLM
14	1	P680410	Fused Power Connector
15	1	P530807	Fuse, 5a, 250v 20mm Slow Blow
16	1	P673820	M800XLC Table Top
17	54	P840511	#6 Lockwasher, Internal Tooth
18	32	P840415	6-32 X 1/4 Pan Head Slotted Machine Screw
19	22	P680721	6-32 X 1/2" Standoff M/F
20	4	P680124	Standoff,6-32x9/16 M/F Black Aluminum
21	22	P840725	#6-32 Small Pattern Hex Nut

ELECTRONICS ENCLOSURE

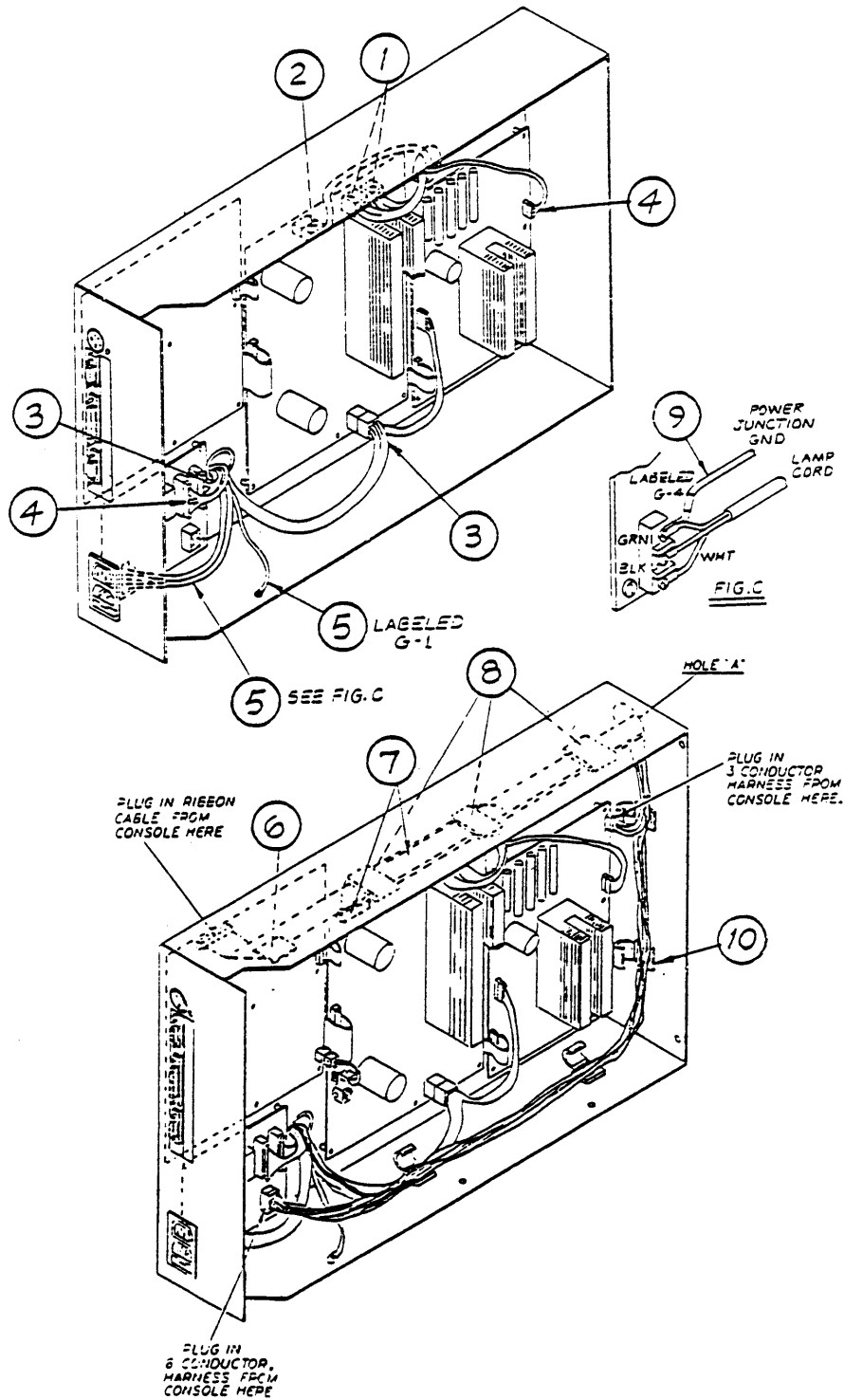

From the library of: Diamond Needle Corp

ELECTRONICS ENCLOSURE

Item	Qty	Part No.	Description
1	-	-----	From Pantograph: X&Y Stepper Motors
2	1	P680740	Harness, XY Limit Switch
3	-	-----	Wire Harness From Control Transformer
4	-	-----	Wire Harness From Isolation Transformer
5	1	P683742	M800XLC Ground Harness
6	1	P520085	Flat Wire Clip, Adhesive Backed
7	1	P683745	Head Interface Cable, XLC
8	3	P320024	Adhesive Mounts- Rectangle
9	-	-----	Detail Of M800XLC Ground Harness
10	5	P670911	#021-0500 Stick On Cable Clamp

SEWING HEAD ASSEMBLY: VIEW 1

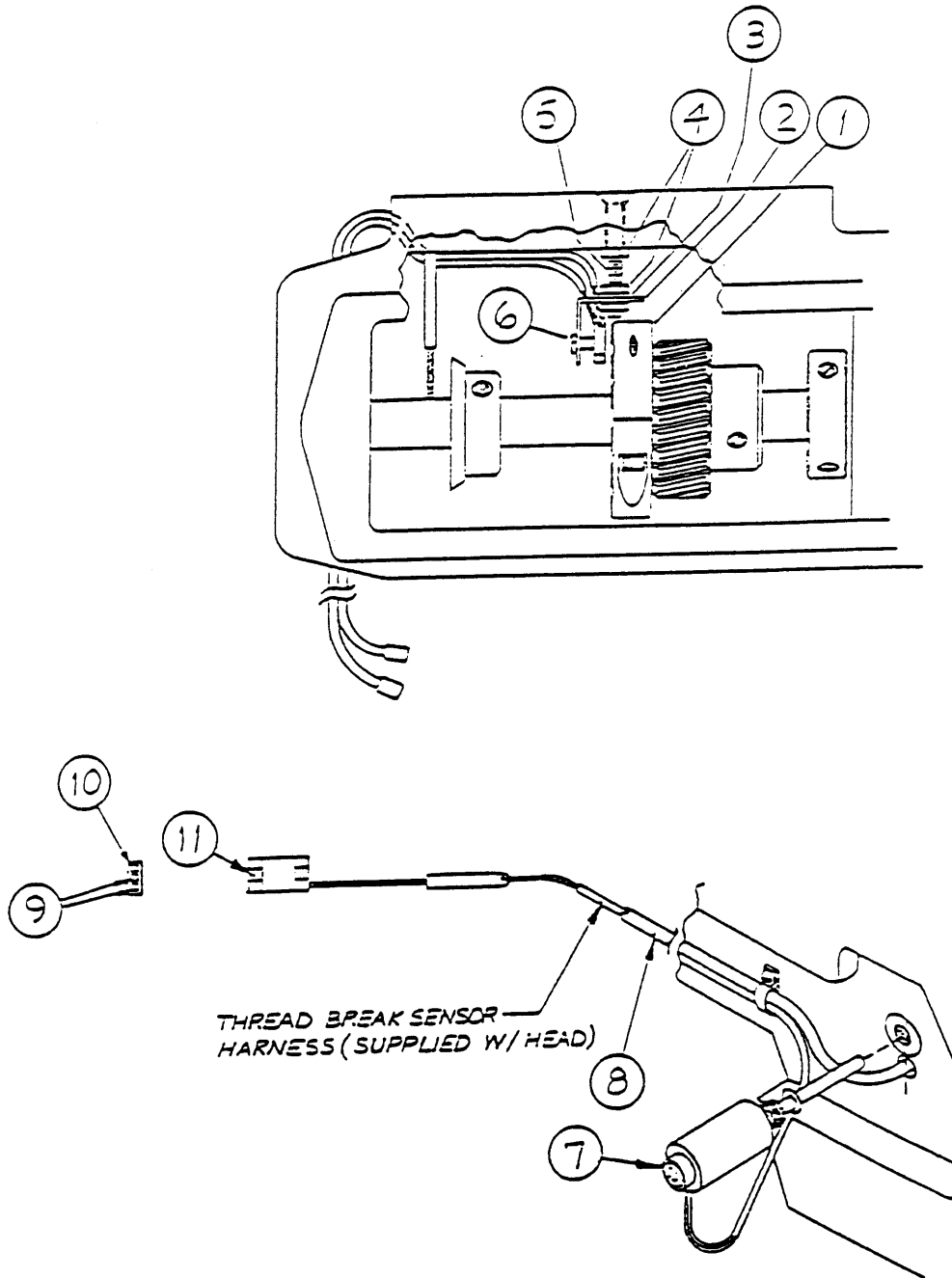

From the library of: Diamond Needle Corp

SEWING HEAD ASSEMBLY: VIEW 1

Item	Qty	Part No.	Description
1	1	ZP614030	PT/NPS Sender Assy
2	1	ZP614040	PT/NPS Pickup Assy
3	1	P840523	#8 Lockwasher, Split
4	3	P840730	8-32 Hex Nut
5	1	P840123	8-32 X 1 1/4 Slotted Flat Head Stainless Screw
6	3	P840401	4-40 X 1/8 Slotted Pan Head Screw
7	1	ZP661200	Tension Release Solenoid Assy
8	1	9P820375	1/8 Shrink Tubing Bulk
9	1	P680250	Head Cable Junction Board, M800/XLM
10	1	9P530010	Polarizing Key
11	1	P820562	3 Circuit Housing

SEWING HEAD ASSEMBLY: VIEW 2

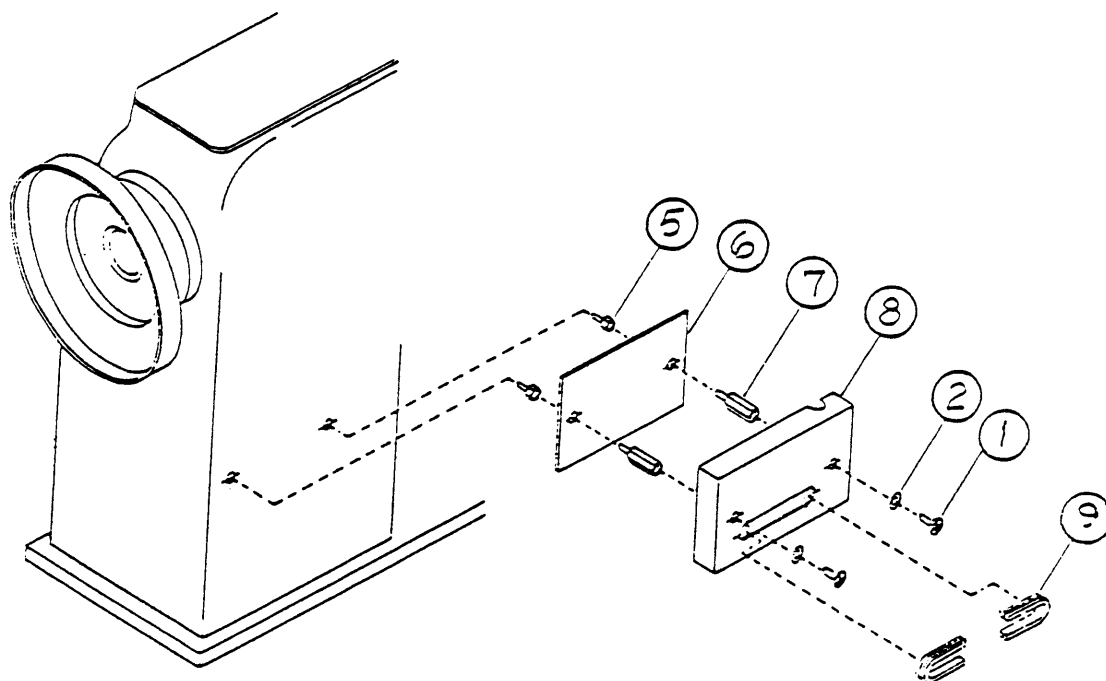
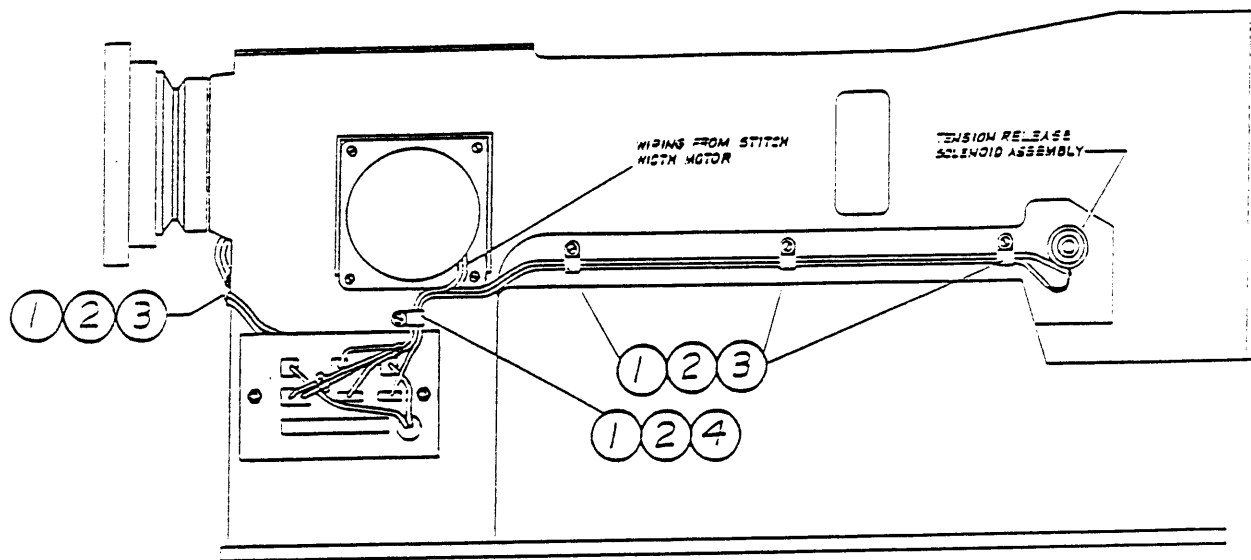

From the library of: Diamond Needle Corp

SEWING HEAD ASSEMBLY: VIEW 2

Item	Qty	Part No.	Description
1	8	P840410	6-32 X 3/8 Slotted Pan Head Screw
2	8	P840510	#6 Flat Washer
3	3	P820061	3/16 Cable Clip
4	1	P820059	3/8" Cable Clip
5	2	P413035	1/4 Hex X 5/16 Long 6-32 Stud Spacer
6	1	P680250	Head Cable Junction Board, M800/XLM
7	2	P614003	#6-32 X 3/4 Male-Female Hex Standoff
8	1	P614038	Cover, Interface Card
9	2	P840916	Rubber Grommet - Z-633

XLC SEWING HEAD PARTS: VIEW 1

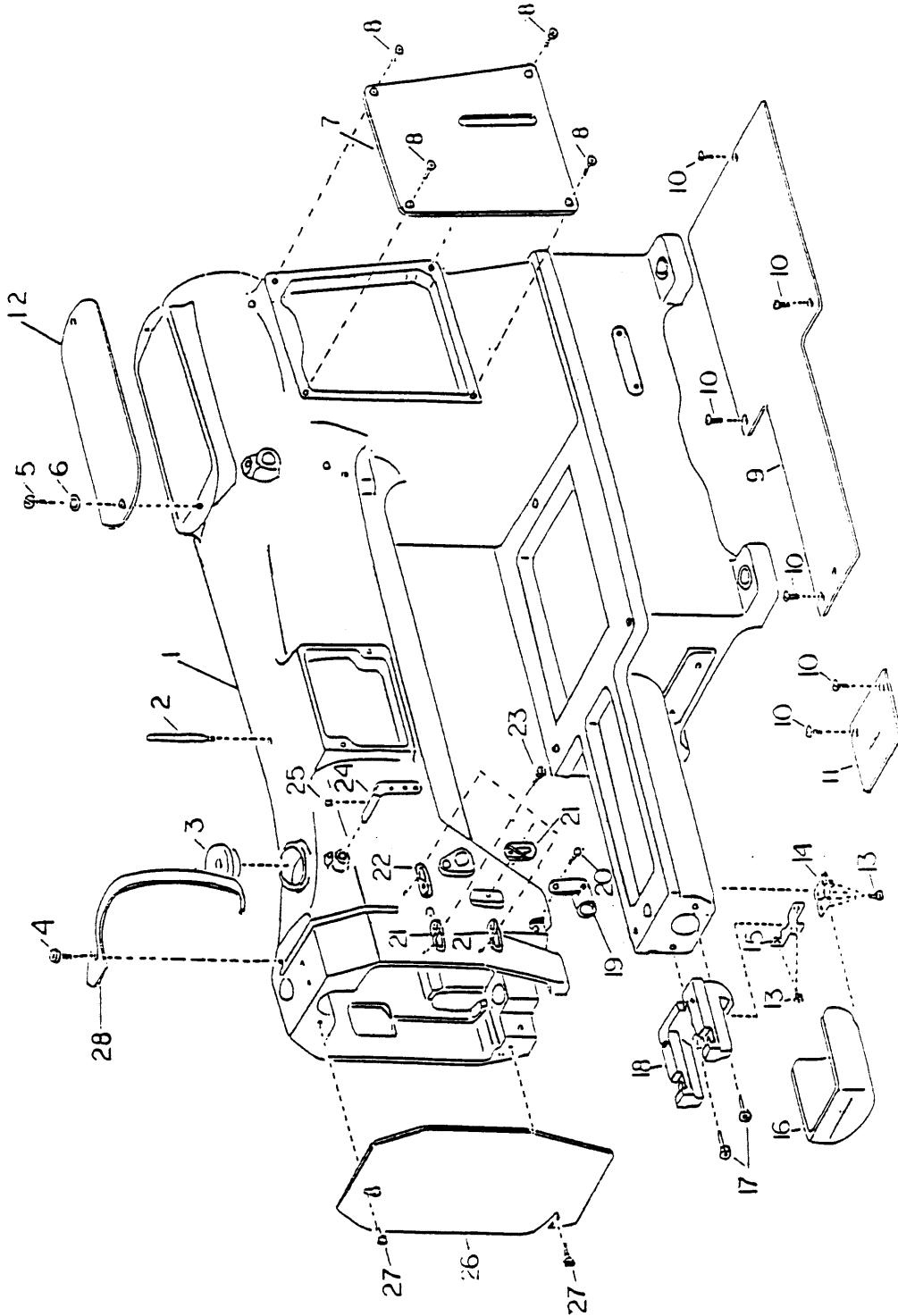

From the library of: Diamond Needle Corp

XLC SEWING HEAD PARTS: VIEW 1

Item	Qty	Part No.	Description
1	1	ZP661000	Cylinder Arm Head
2	1	P661039	Thread Guide, Top
3	1	P661074	Oil Plug
4	1	P661073	M4 X 6 X 0.7 Phillips Truss Head Screw
5	1	P661076	Screw, Top Cover Plate
6	1	P661077	Wavey Washer 6.4 ID X 11 OD
7	1	P661078	Stitch Width Cover
8	4	P661079	M4 X 8 X 0.7 Phillips Flat Head Screw
9	1	P661082	Work Plate
10	6	P661081	11/64-40 X 9 Slot Oval
11	1	P661080	Throat Plate
12	1	P661075	Top Cover Plate
13	2	P661086	M3 X 5 X 0.5 Phil Pan Head Screw
14	1	P661085	Hook Cover Hinge
15	1	P661087	Hook Cover Catch
16	1	P661084	Hook Cover
17	1	P661008	M5 X 14 X 0.8 Socket Cap Screw
18	1	P661007	Needle Plate Bracket
19	1	P413865	Spring Loaded Thread Guide
20	1	P661069	9/64-40 X 6 Slot Flat Head Screw
21	3	P661043	Front Thread Guide
22	1	P661044	Rear Thread Guide
23	4	P661045	9/64-40 X 8 Slot Pan Head Screw
24	1	P661040	Thread Guide, 3-hole
25	1	P661041	M4 X 4 X 0.7 Socket Set Screw
26	1	P661070	Face Plate
27	2	P661045	9/64-40 X 8 Slot Pan Head Screw
28	1	P661072	Take-Up Lever Guard

XLC SEWING HEAD PARTS: VIEW 2

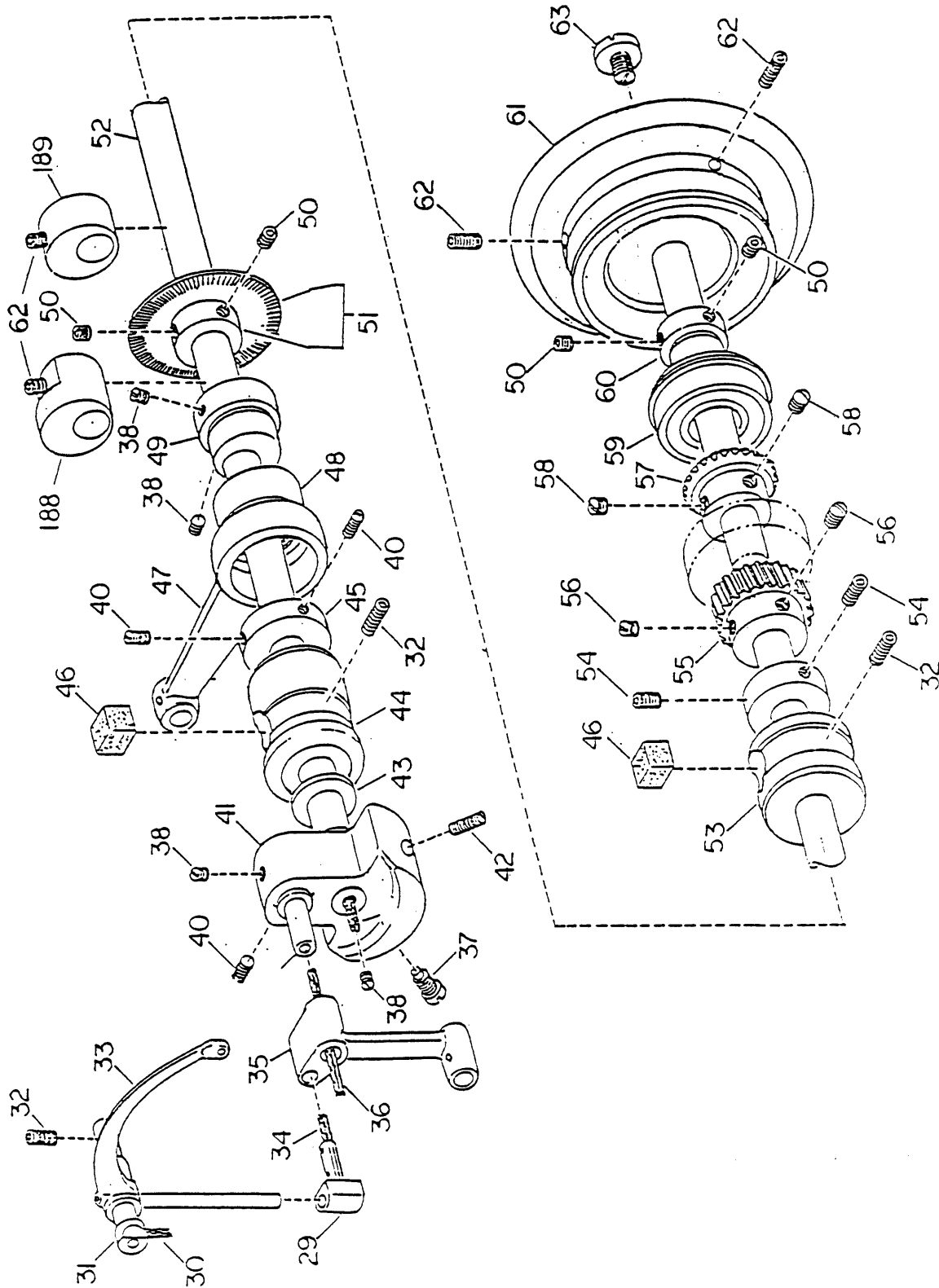

XLC SEWING HEAD PARTS: VIEW 2

Item	Qty	Part No.	Description
29	1	P413559	Take Up Lever Drive Stud
30	1	P661095	Oil Wick, 3.5 Dia. X 45 Long
31	1	P413555	Take Up Lever Hinge Stud
32	3	P661094	M6 X 10 X 1.0 Socket Set Screw
33	1	P413650	Take Up Lever
34	1	P661097	Oil Wick, 3.5 Dia. X 25 Long
35	1	P413274	Needle Bar Connecting Link
36	1	P661099	Oil Wick, 3.5 Dia. X 55 Long
37	1	P661104	9/32-28 X 11 Screw
38	2	P661102	15/64-28 X 4.5 Slot Set Screw
39	1	P413269	Needle Bar Connecting Link Stud
40	1	P661101	15/64-28 X 7 Slot Set Screw
41	1	P661103	Needle Bar Crank
42	1	P661105	15/64-28 X 13 Slot Set Screw
43	1	P661106	Crank Friction Washer
44	1	P413310	Armshaft Bushing Front
45	1	P661113	Collar, Front
46	2	P661112	Oil Pad
47	1	P413472	Eccentric/Cam
48	1	P413473	Needle Bearing
49	1	P413471	Lifting Eccentric
50	4	P661038	M6 X 6 X 0.8 Socket Set Screw
51	1	P661119	Winder Friction Disc
52	2	P661107	Arm Shaft
53	1	P413602	Armshaft Bushing Middle
54	2	P661125	M6 X 8 X 1.0 Socket Set Screw
55	1	P413751	Feed Collar
56	2	P413609	1/4-40 X 6 Slot Set Screw
57	1	P661128	Arm Shaft Gear, Spiral
58	2	P413609	1/4-40 X 6 Slot Set Screw
59	1	P661130	Arm Shaft Bearing, Rear
60	1	P661131	Collar, Arm Shaft Bearing
61	1	P661133	Balance Wheel
62	2	P661134	M6 X 12 X 1.0 Socket Set Screw
63	1	P661135	5/16-24 X 15 Slot Truss Head Screw

XLC SEWING HEAD PARTS: VIEW 3

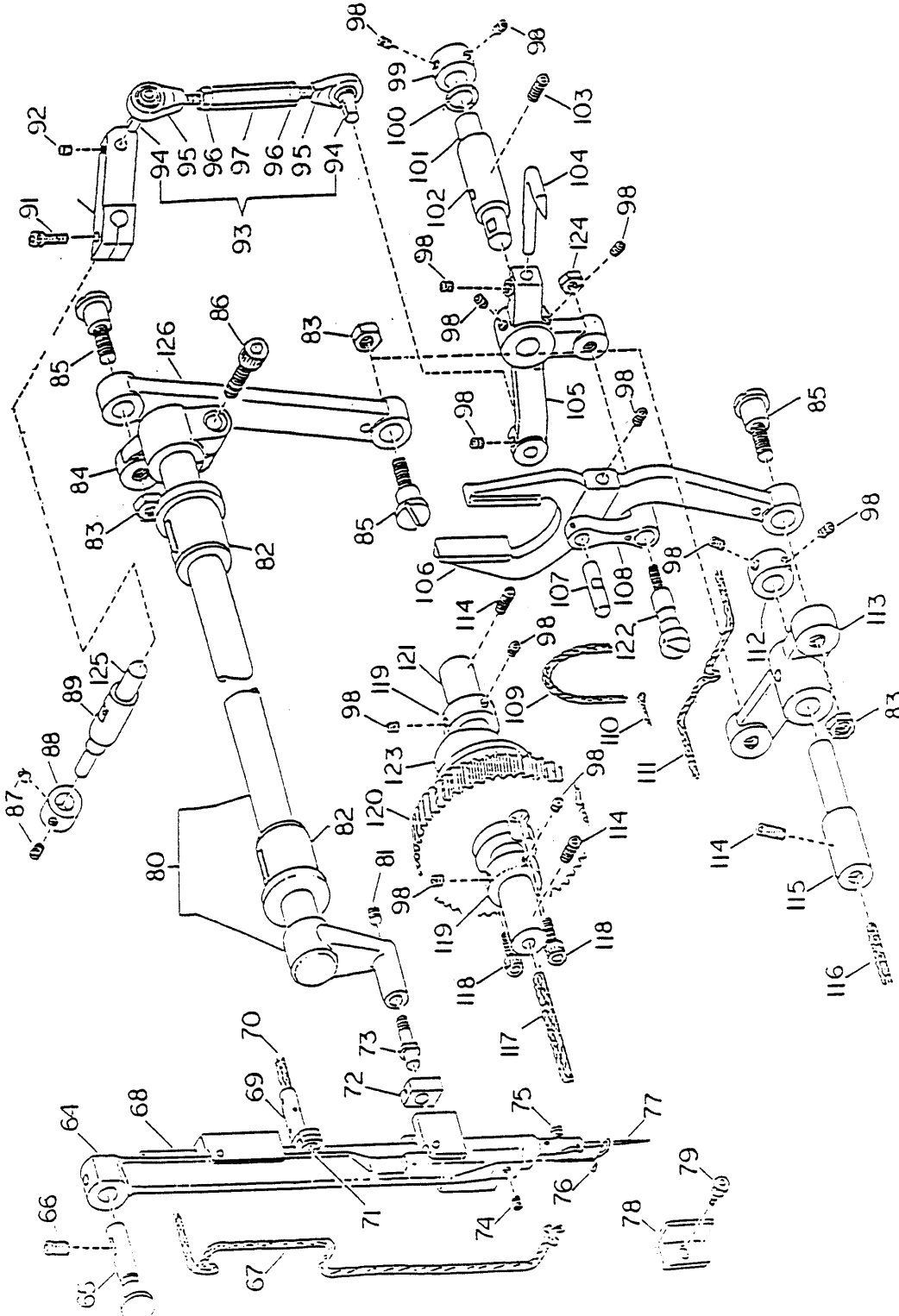

From the library of: Diamond Needle Corp

XLC SEWING HEAD PARTS: VIEW 3

Item	Qty	Part No.	Description
64	1	P642510	Needle Bar Frame
65	1	P413527	Hinge Pin
66	1	P661094	M6 X 10 X 1.0 Socket Set Screw
67	1	P661139	Oil Wick, 3.5 Dia. X 270 Long
68	1	P661144	Needle Bar
69	1	P413278	Needle Bar Connecting Stud
70	1	P661147	Oil Wick, 3.5 Dia. X 35 Long
71	1	P413279	Screw
72	1	P413330	Needle Bar Frame Slide Block
73	1	P413328	Needle Bar Frame Block Stud
74	1	P661041	M4 X 4 X 0.7 Socket Set Screw
75	1	P413535	Needle Screw
76	1	P413860	XL Arm Lower Thread Guide New
77	1	See Cat	Needle
78	1	P413308	Needle Bar Frame Position Bracket
79	1	P661141	M4 X 6 X 0.7 Socket Cap Screw
80	1	P661150	Needle Bar Rock Frame Shaft
81	1	P413329	Set Screw
82	2	P661154	Rock Frame Shaft Bushing
83	2	P413247	Hinge Nut
84	1	P661155	Needle Bar Shaft Crank
85	2	P413660	Hinge Screw
86	1	P661156	M6 X 20 X 1.0 Socket Cap Screw
87	2	P661195	Set Screw, Collar
88	1	P661194	Collar, Coupling Shaft
89	1	P413735	Bushing, Coupling Drive
90	1	P661190	Lifting Crank
91	1	P661024	M4 X 12 X 0.7 Socket Cap Screw
92	1	P661041	M4 X 4 X 0.7 Socket Set Screw
93	1	P661184	Stitch Width Rod Assembly
94	2	P413776	Bearing Pin
95	2	P413775	Bearing Pin Connecting Bracket
96	2	P413206	Lock Nut
97	1	P661185	Stitch Width Arm
98	12	P661163	M5 X 5 X 0.8 Socket Set Screw
99	1	P661182	Collar

100	1	P661181	Wavey Washer
101	1	P413763	Support Shaft
102	1	P413764	Support Shaft Bushing
103	1	P661094	M6 X 10 X 1.0 Socket Set Screw
104	1	P413767	Stitch Width Indicator
105	1	P661175	Stitch Width Regulating Arm
106	1	P413758	Stitch Width Cam Follower
107	1	P413760	Shaft
108	1	P413759	Pivot Lock
109	1	P661171	Oil Wick, 3.5 Dia. X 75 Long
110	1	P413585	Cotter Pin
111	1	P661167	Oil Wick, 3.5 Dia. X 200 Long
112	1	P661162	Thrust Collar
113	1	P413782	Pivot Connecting Bracket
114	2	P661094	M6 X 10 X 1.0 Socket Set Screw
115	1	P413783	Pivot Shaft
116	1	P661095	Oil Wick, 3.5 Dia. X 45 Long
117	1	P661201	Oil Wick, 3.5 Dia. X 100 Long
118	2	P661008	M5 X 14 X 0.8 Socket Cap Screw
119	2	P661202	Shaft Collar
120	1	P413752	Stitch Width Drive Gear
121	1	P413754	Stitch Width Cam Shaft
122	1	P661173	Pivot Link Shoulder Screw
123	1	P413753	Stitch Width Cam
124	1	P661174	15/64-28 Hex Nut
125	1	P413779	Coupling Drive Shaft
126	1	P413784	Needle Bar Rock Shaft Crank Connector

NOTES

From the library of: Diamond Needle Corp

XLC SEWING HEAD PARTS: VIEW 4

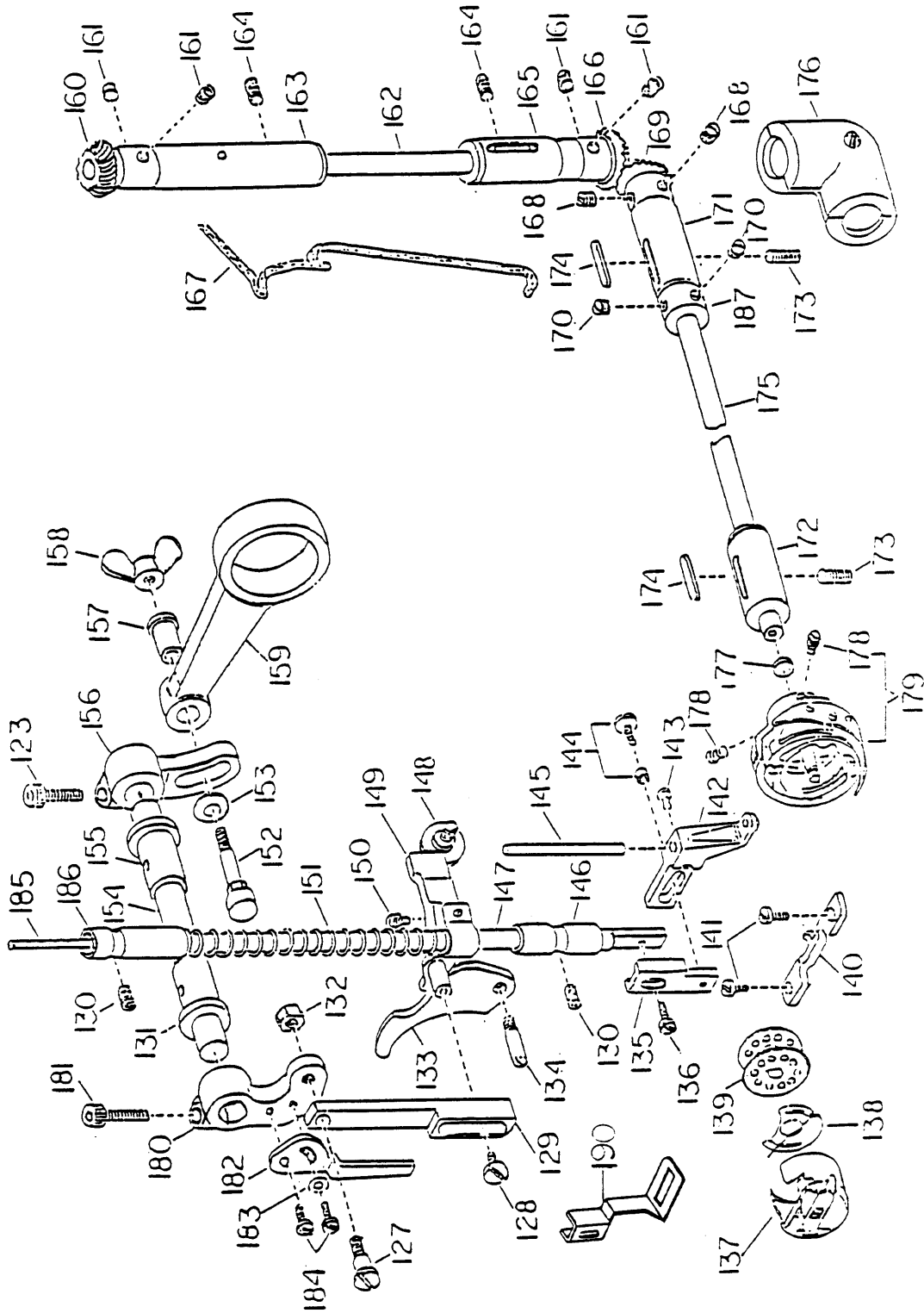

From the library of: Diamond Needle Corp

XLC SEWING HEAD PARTS: VIEW 4

Item	Qty	Part No.	Description
127	1	P413539	Connecting Link Shoulder Screw
128	1	P661237	Screw, Lift Link
129	1	P661234	Presser Bar Lift Link
130	2	P661221	M6 X 8 X 1.0 Socket Set Screw
131	2	P413260	Sleeve Bushing
132	1	P413249	Nut
133	1	P661222	Presser Bar Lifter Lever
134	1	P661223	Presser Bar Lifter Hinge Screw
135	1	P661231	Connecting Link
136	1	P413847	Presser Foot Screw
137	1	P413830	Bobbin Case XL
138	1	P413835	XL Overspin Protector
139	1	P413670	Bobbin XL
140	1	P661260	Hook Position Finger
141	2	P661045	9/64-40 X 8 Slot Pan Head Screw
142	1	P641503	Jump Foot
143	1	P661229	Screw, Jump Foot
144	1	P661233	Screw/Spacer
145	1	P642501	Jump Foot Rod
146	1	P661220	Presser Bar Bushing, Lower
147	1	P661217	Presser Bar
148	1	P661226	Shoulder Screw
149	1	P661224	Presser Bar Guide Bracket
150	1	P661225	Screw, Guide Bracket
151	1	P661227	Spring, Presser Bar
152	1	P661210	Shoulder Screw
153	1	P661209	Thrust Washer
154	1	P413788	Eccentric Cam Link Shaft
155	2	P413260	Sleeve Bushing
156	1	P661206	Eccentric Cam Link, Left
157	1	P413474	Sleeve
158	1	P661211	Wing Nut
159	1	P413472	Eccentric/Cam
160	1	P661243	Armshaft Upright Gear, Upper
161	4	P661244	Set Screw, 1/4-40 X 5
162	1	P661238	Arm Shaft, Upright

163	1	P413614	Upright Shaft Bushing, Upper
164	2	P661094	M6 X 10 X 1.0 Socket Set Screw
165	1	P413615	Upright Shaft Bushing, Lower
166	1	P661245	Armshaft Upright Gear, Lower
167	1	P661108	Oil Wick, 3.5 Dia. X 160
168	2	P661244	Set Screw, 1/4-40 X 5
169	1	P661247	Lower Shaft Gear
170	2	P661256	Set Screw, Collar
171	1	P661252	Hook Shaft Bushing, Rear
172	1	P661251	Hook Shaft Bushing, Front
173	1	P661094	M6 X 10 X 1.0 Socket Set Screw
174	2	P661253	Felt Pad
175	1	P661250	Hook Shaft
176	1	P661249	Lower Gear Housing
177	1	P661259	Felt Pad
178	2	P413827	XL Hook Screw
179	1	P413820	Hook Assembly XL
180	1	P661212	Eccentric Cam Link
181	2	P661207	M6 X 15 X 1.0 Socket Cap Screw
182	1	P661214	Trip Lever
183	1	P661216	Washer
184	2	P661045	9/64-40 X 8 Slot Pan Head Screw
185	1	P661218	Oil Wick, 3.5 Dia. X 150 Long
186	1	P413284	Presser Bar Bushing
187	1	P661255	Collar, Hook Shaft
188	1	P661268	Front Armshaft Counterweight
189	1	P661267	Rear Armshaft Counterweight
190	1	P661269	XLC Large Presser Foot

NOTES

From the library of: Diamond Needle Corp

TENSION AND BOBBIN WINDER TENSION ASSEMBLY

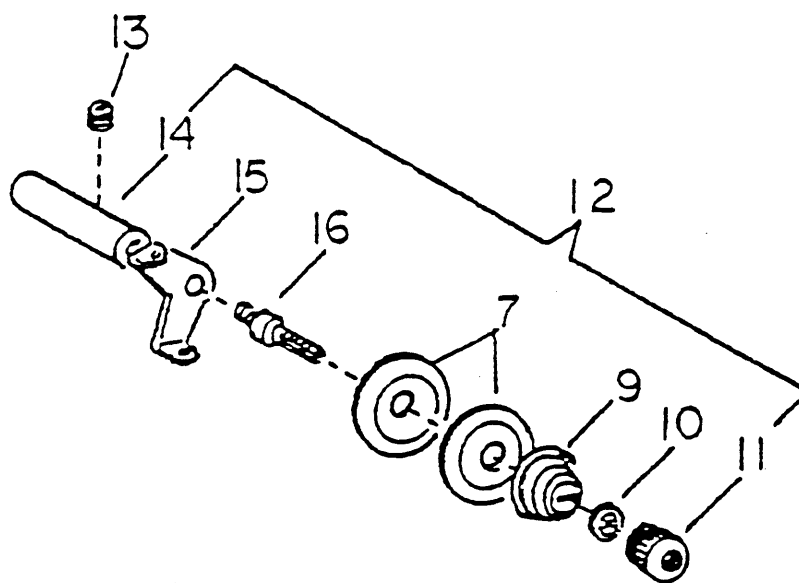
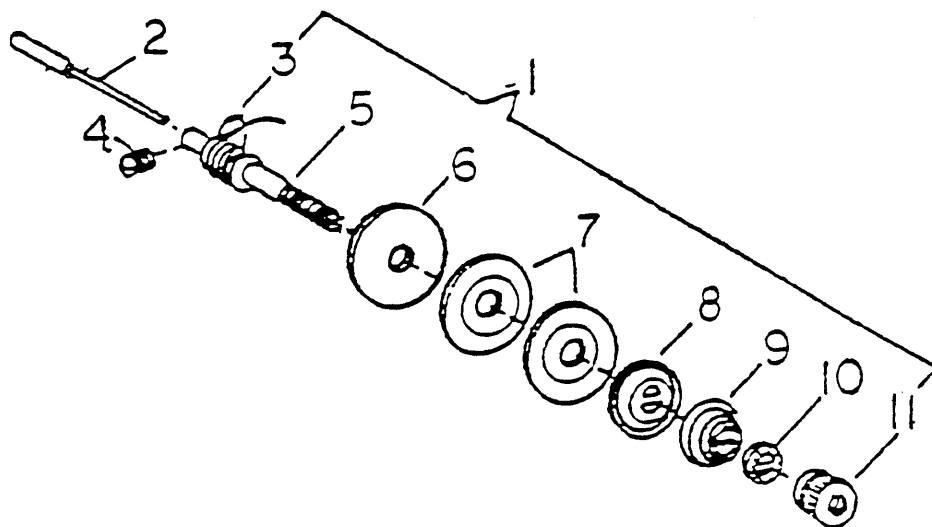

From the library of: Diamond Needle Corp

TENSION AND BOBBIN WINDER TENSION ASSEMBLY

Item	Qty	Part No.	Description
1	1	P661052	Tension Assembly Complete
2	1	P661062	Tension Release Push Rod
3	1	P661061	M4 X 8 X 0.7 Socket Set Screw
4	1	P661054	Check Spring
5	1	P661053	Tension Stud
6	1	P661055	Insulating Disc
7	2	P661034	Tension Disc
8	1	P661057	Tension Release Disc
9	1	P661035	Tension Spring
10	1	P661036	Tension Nut Washer
11	1	P661037	Tension Nut
12	1	P661030	Winder Tension Assembly
13	1	P661038	M6 X 6 X 0.8 Socket Set Screw
14	1	P661031	Tension Post
15	1	P661032	Winder Thread Guide
16	1	P661033	Winder Tension Stud

BOBBIN WINDER ASSEMBLY, XLC

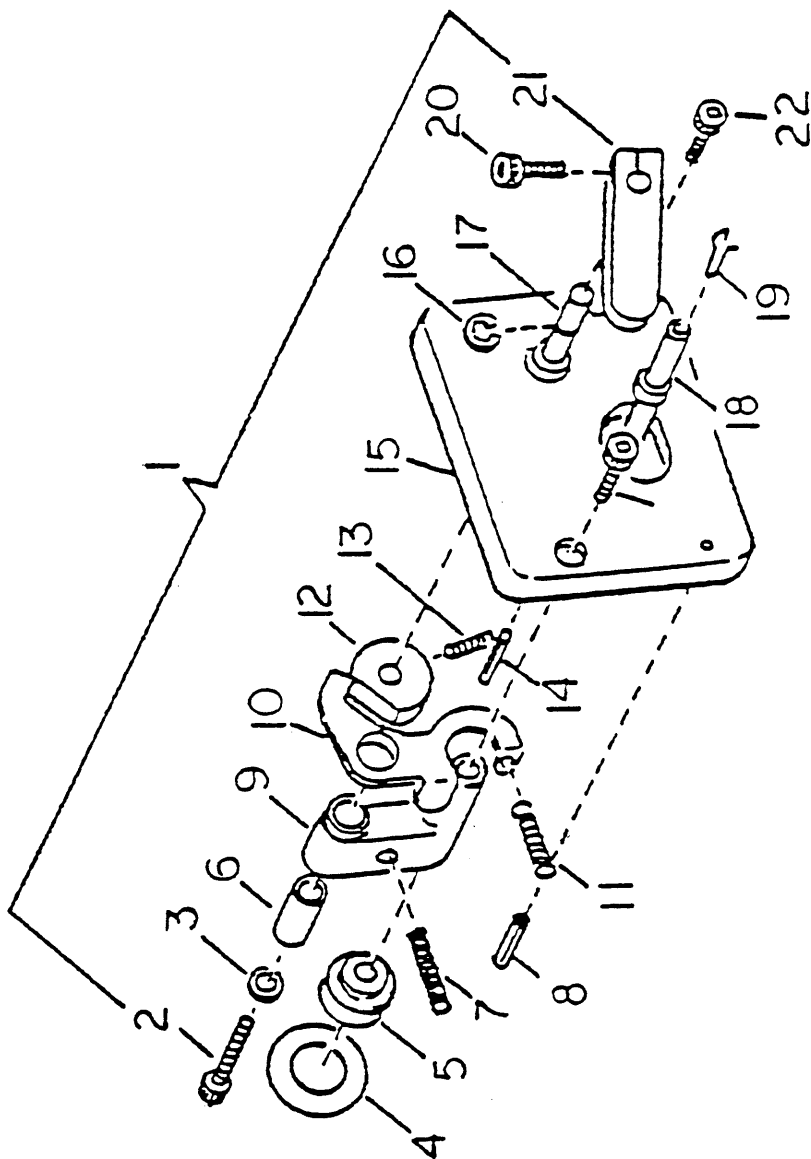

From the library of: Diamond Needle Corp

BOBBIN WINDER ASSEMBLY, XLC

Item	Qty	Part No.	Description
1	1	P661009	XLC Bobbin Winder
2	1	P661023	M4 X 20 X 0.7 Socket Cap Screw
3	1	P661025	M4 Flat Washer
4	1	P661028	O-ring 15 ID X 25 OD
5	1	P661017	Winder Wheel
6	1	P661012	Pivot Link Bushing
7	1	P661013	Bobbin Winder Spring
8	2	P661026	Roll Pin 3.5 Dia. X 16
9	1	P661011	Bobbin Winder Pivot Link
10	1	P661014	Winder Trip Lever
11	1	P661015	Winder Trip Spring
12	1	P661021	Winder Trip Lever Cam
13	1	P661022	Winder Cam Stop Screw
14	1	P661026	Roll Pin 3.5 Dia. X 16
15	1	P661010	Bobbin Winder Mounting Plate
16	1	P661027	C-Clip
17	1	P661020	Winder Trip Arm Shaft
18	1	P661016	Bobbin Winder Shaft
19	1	P661018	Bobbin Key
20	1	P661024	M4 X 12 X 0.7 Socket Cap Screw
21	1	P661019	Winder Trip Arm
22	2	P661029	M4 X 10 X 0.7 Socket Cap Screw

STITCH WIDTH ASSEMBLY, XLC

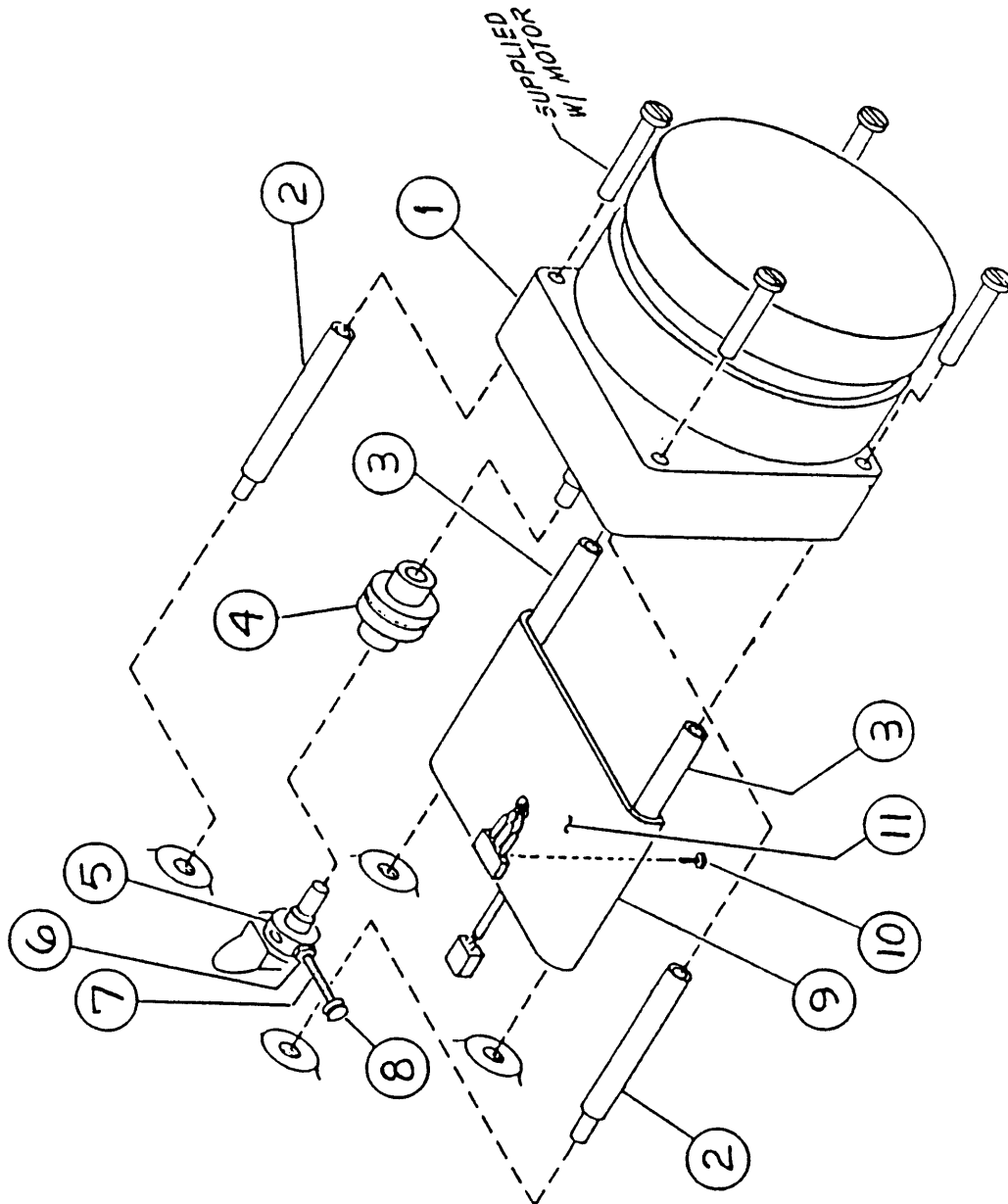

From the library of: Diamond Needle Corp

STITCH WIDTH ASSEMBLY, XLC

<u>Item</u>	<u>Qty</u>	<u>Part No.</u>	<u>Description</u>
1	1	P614050	Stitch Width Motor Assembly
2	2	P413004	Support Post 2" Long
3	2	P413003	Support Post 1 3/4" Long
4	1	P312013	Coupling, Stitch Width Motor
5	1	P413780	Drive Shaft Collar
6	1	P840715	Nut, 4-40 Hex
7	1	P840405	Screw, 4-40 X 3/4 Slotted Pan Head
8	1	P413018	Magnet
9	1	P614052	Bracket, Stitch Width Limit Sensor
10	3	P840401	Screw, 4-40 X 1/8 Slotted Pan Head
11	1	P614025	Stitch Width Limit Sensor Assembly

PANTOGRAPH ASSEMBLY

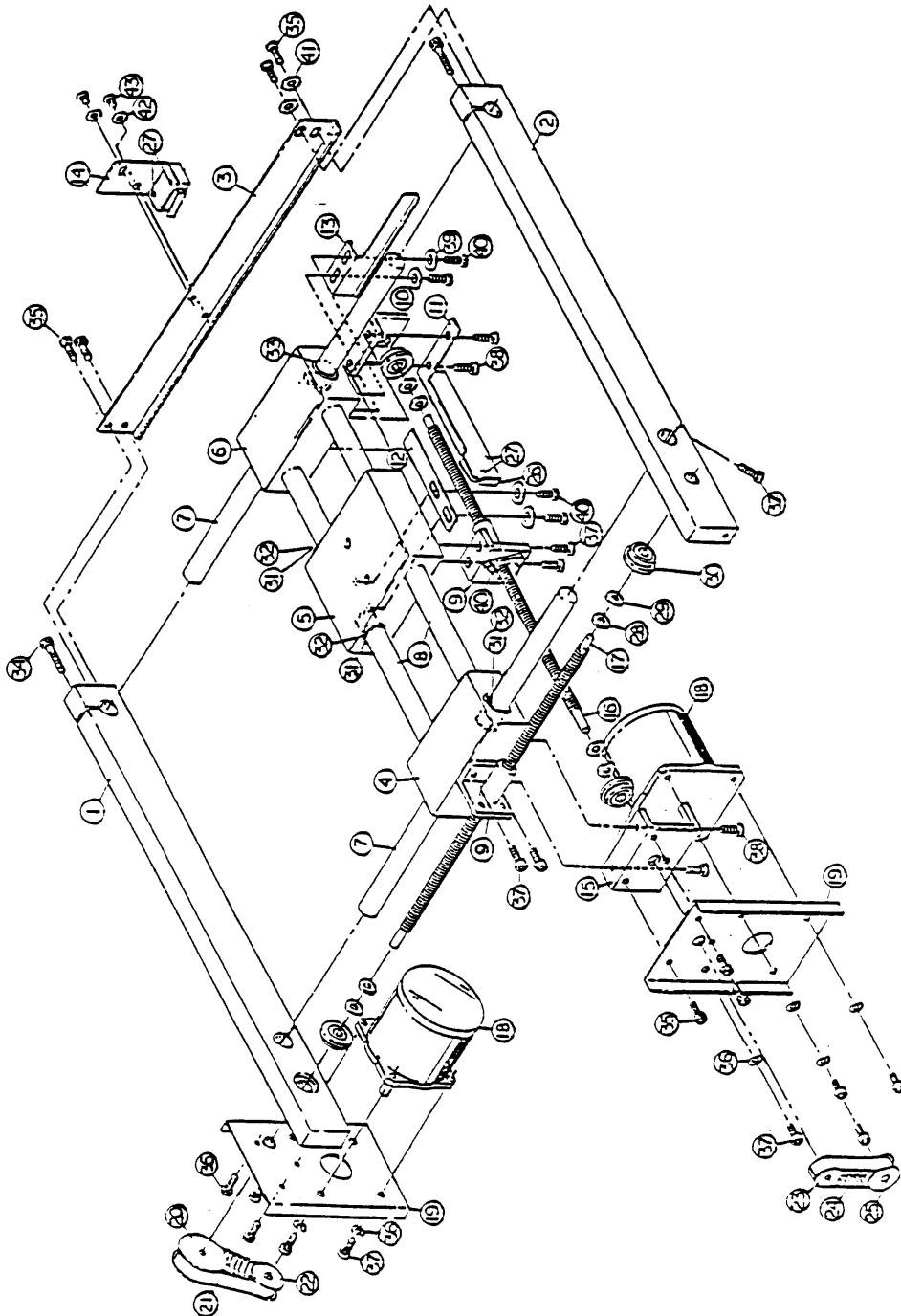

From the library of: Diamond Needle Corp

PANTOGRAPH ASSEMBLY

Item	Qty	Part No.	Description
1	1	P520402	Right Pantograph Rail
2	1	P520401	Left Pantograph Rail
3	1	P620403	Support
4	1	P520413	Block, Motor End - Pantograph
5	1	P520421	Block, Center- Pantograph
6	1	P520441	Block, Free End - New Pantograph
7	2	P420426	26" Pantograph Bar
8	2	P520419	Bar Guide - X Axis
9	2	P520425	Support, Lead Screw Nut- Pantograph
10	1	P520439	Support, Leadscrew - New Pantograph
11	1	P520468	Bracket, Switch, X-Axis
12	1	P520466	Actuator,switch, X-Axis
13	1	P620409	Actuator, Limit Switch
14	1	P620405	Bracket, Switch, X-Axis
15	1	P520433	Support, Motor New Pantograph
16	1	P520427	Lead Screw Pantograph
17	1	P620407	Lead Screw X-Axis
18	2	P670410	Stepper Motor, M800 Series
19	2	P620419	Motor Mount -heavy Duty
20	1	P620413	Pulley, 5/16" Bore 28XL037
21	1	P520431	Belt, Timing Large (100XL037)
22	1	P620415	Pulley, 3/8" bore 14XL037
23	1	P620417	Pulley, 5/16" Bore 16XL037
24	1	P520407	Belt, Timing (90XL037) Small
25	1	P620411	Pulley, 3/8" bore 16XL037
26	2	P520404	Stepper Motor Limit Switch
27	4	P840407	4-40x1/2 Slotted Pan Head Screw
28	4	P520412	Washer, Thrust - New Pantograph
29	4	P520435	Washer, Spring - New Pantograph
30	4	P520411	Bearing, Flanged - New Pantograph
31	6	P520415	Retaining Ring-new Pantograph
32	6	P520417	Bushing, Pantograph
33	2	P520423	Bushing, Ball
34	2	P840056	1/4-20 X 1 1/4 Sock Head Screw
35	6	P840049	1/4-20 X 3/8 Sock Head Screw
36	8	P840580	1/4" Lock Washer

37	14	P840052	1/4-20 X 1/2 Socket Head Screw
38	4	P840077	Screw, Socket Head 5/16-18 x 1 1/2 Long
39	1	P840530	Washer, Flat #10
40	10	P840073	Screw, Socket Head 10-32 X 3/8 Long
41	2	P840540	1/4" SAE Flat Washer-Plated
42	6	P840520	#8 Flat Washer
43	2	P840417	8-32 x 3/16 Pan Head Slotted Screw

Meistergram[®]
THE PERSONALIZATION PEOPLE™

M800 SERIES

USER MANUAL

APPENDIX

JUMP FOOT CONVERSION

THE SEWING HEAD IS ORIGINALLY EQUIPPED WITH THE JUMP FOOT.
THE FOLLOWING INSTRUCTIONS ARE FOR REMOVAL OF THE JUMP
FOOT AND INSTALLATION OF THE LARGE PRESSER FOOT.

Tools Required (supplied in machine tool kit)

- Slot Head Screwdriver
- Allen Wrench 3/32 inch
- Allen Wrench .05 inch

STEP 1

Rotate the Handwheel so that the needle is in the UP position.

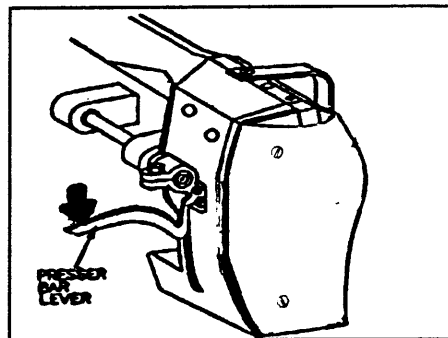

Presser Bar Lever - fig. 1

STEP 2

Lower the Presser Bar Lever to the Down position. (See fig. #1.) Remove the front cover from the Sewing Head.

STEP 3

With the Slot Head Screwdriver, remove the Thumbscrew that holds the Jump Foot Link to the Presser Bar. (See fig. Jump Foot Link.) Save the Thumbscrew for use in step 7.

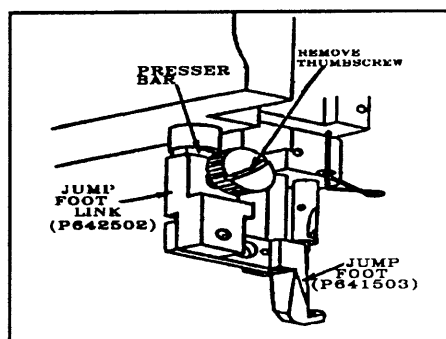

Jump Foot Link - fig. 2

STEP 4

With the 3/32 inch Allen Wrench, loosen, **DO NOT REMOVE** the Socket Head Screw located on the rear of the Jump Foot. (See fig. Socket Head Screw.)

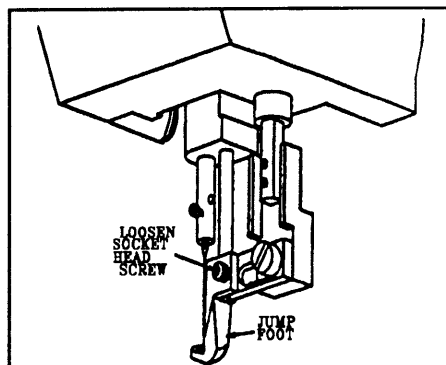

Socket Head Screw - fig. 3

STEP 5

Remove the Jump Foot/Jump Foot Link from the Presser Bar.

JUMP FOOT CONVERSION

THE SEWING HEAD IS ORIGINALLY EQUIPPED WITH THE JUMP FOOT.
THE FOLLOWING INSTRUCTIONS ARE FOR REMOVAL OF THE JUMP
FOOT AND INSTALLATION OF THE LARGE PRESSER FOOT.

STEP 6

Supplied in the machine tool kit is a Nylon Tipped Set Screw. With the .05 inch Allen Wrench, install this Set Screw into the hole in the Needle Bar Frame as shown in fig. 4. DO NOT tighten it in place yet. Push the Jump Foot Bar up until approximately 1/8 of an inch of it protrudes from the bottom of the Needle Bar Frame. (See fig. Needle Bar Frame.) Tighten the Nylon Tipped Set Screw to hold the Jump Foot Bar in place.

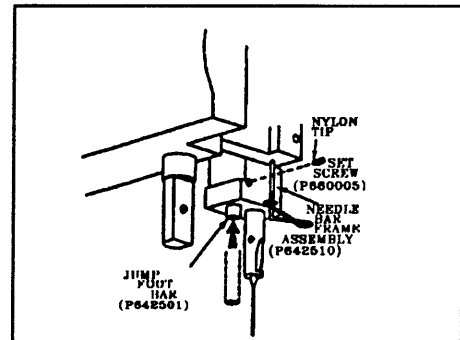

Needle Bar Frame - fig. 4

STEP 7

Attach the Large Presser Foot to the hole in the Presser Bar with the Thumbscrew removed in step 3. (See fig. #5.) Replace the front cover on the Sewing Head. Adjust the Large Presser Foot for desired height using the Thumbscrew. (refer to "Adjusting the Presser Foot" on Pg. 65)

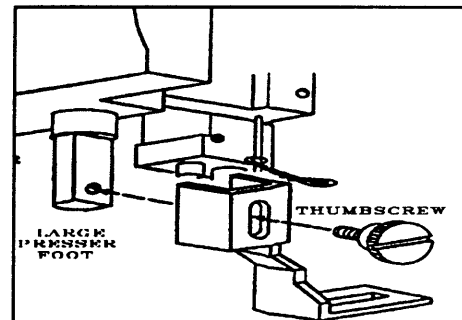

Presser Foot Attachment- fig. 5

JUMP FOOT CONVERSION

THE FOLLOWING INSTRUCTIONS ARE FOR REMOVAL OF THE LARGE PRESSER FOOT AND INSTALLATION OF THE JUMP FOOT.

STEP 1

Turn the Handwheel so that the needle is in the UP position.

STEP 2

Move the Presser Bar Lever to the DOWN position. Remove the front cover of the Sewing Head.

STEP 3

With the Slot Head Screwdriver, remove the Thumbscrew that holds the Large Presser Foot to the Presser Bar. Remove the Large Presser Foot from the Presser Bar.

STEP 4

With the 0.05 inch Allen Wrench, remove the Nylon Tipped Set Screw from the Needle Bar Frame.

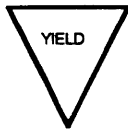

CAUTION:

- The nylon tipped Set Screw **MUST** be removed from the Needle Bar Frame to avoid serious damage to the Sewing Head.

STEP 5

While aligning the Jump Foot, push the Jump Foot Bar completely into the hole in the top of the Jump Foot. With the 3/32 inch Allen Wrench, tighten the Socket Head Screw at the rear of the Jump Foot to secure the Jump Foot Bar in place.



NOTE:

- Make sure that the Jump Foot Bar is fully seated by visually inspecting the bottom of the Jump Foot.

JUMP FOOT CONVERSION

THE FOLLOWING INSTRUCTIONS ARE FOR REMOVAL OF THE LARGE PRESSER FOOT AND INSTALLATION OF THE JUMP FOOT.

STEP 6

Using the slot head screwdriver, attach the Jump Foot Link to the hole on the Presser Bar with the Thumbscrew. Replace the front cover of the Sewing Head. Adjust the Jump Foot for desired height using the Thumbscrew. (refer to "Adjusting the Presser Foot", Pg. 65)

MACHINE SPECIFICATIONS

	M800XLM	M800 XLC
SEWING FIELD	9"X18"	9"X18"
DEPTH	30"	30"
WIDTH	48"	51"
HEIGHT	37"	37"
WEIGHT	350 Lbs	350 Lbs
SHIPPING WEIGHT	650 Lbs	650 Lbs
ELECTRICAL	110 Volts 60 Cycle	110 Volts 60 Cycle
REQUIREMENTS	Max. Amps-6 NHC*	Max. Amps-6 NHC*

*Normal Household Current

PRINTER RECOMMENDATIONS

The following printers have been tested by Meistergram and are known to work. Other models from the same manufacturer will probably work, but we cannot guarantee this. One feature to look for when selecting a particular printer model is "buffer" size. Much like humans, printers can receive (listen to) information from the computer/M800 much faster than they can print (type). A buffer holds the information temporarily and allows the computer to proceed with other commands while the printer is still printing.

EPSON: LX-800

This low cost printer should have its DIP switches configured as follows:

1-1	off	(normal characters)	1-7	on	(select USA character set)
1-2	off	*(unslashed zero)	1-8	on	(select USA character set)
1-3	off	(italics characters)	2-1	off	(11 inch page)
1-4	off	(do detect paper out)	2-2	off	(no cut sheet feeder)
1-5	off	*(draft print quality)	2-3	off	(no perforation skip)
1-6	on	(select USA char. set)	2-4	off	(no AUTO carriage return)

* means optional

HEWLETT PACKARD: LASER JET II

This laser printer is expensive, but gives very high quality printouts. The printouts, however, will be smaller than the other printers. Make sure the printer is set for PARALLEL operation and IBM character set is selected. **THIS PRINTER HAS A DIFFERENT ASPECT RATIO and ANY PRINTOUTS in a screen scale OTHER than "4PRINTER" WILL BE DISTORTED!** No correction for this will be made in software.

Meistergram[®]
THE PERSONALIZATION PEOPLE™

M800 SERIES

USER MANUAL

APPENDIX B: HAT CLAMP

CAP FRAME

The cap frame accessory kit provides the parts you need to produce high quality monogrammed caps quickly and efficiently. Use the following instructions to get the best results:

PAGE	TOPIC
B-2	Introduction
B-3	Cap Frame Parts
B-4	Remove Table Insert
B-4	Install Raised Throat Plate
B-5	Install Cap Frame Drive onto XLC
B-6	Set Sewing Field (on Adjustable Frame)
B-7	Load Cap onto Frame
B-8	Load Frame onto Drive
B-9	Adjust Jump Foot Height
B-10	Final Steps

Use the following CheckList as a reminder of the steps needed to setup your machine to sew hats:

CAP FRAME CHECKLIST

- Remove Table Top Insert
- Install Raised Throat Plate
- Install Cap Frame Drive Unit
- Set Sewing Field (on Adjustable Frame)
- Load Cap onto Frame
- Load Frame onto Drive Unit
- Re-Adjust Jump/Presser Foot Height
- Use "H" Hat Mode command, or program Upside/Down/Backwards
- Program Monogram
- Preview
- Perimeter Trace (watch out for lower case letters!)

MEISTERGRAM CAP FRAME KIT PARTS

The Cap Frame kit is an accessory for your XLC machine and is included in your supply kit (shipped separately from the machine). The Cap Frame Kit is also available as Meistergram Part Number B95400000.

Locate and identify the following parts- which are illustrated below.

QTY	ITEM NUMBER	DESCRIPTION
1	B9540028	DRIVE UNIT
2	B95200010	ADJUSTABLE FRAME
1	B95200100	FRAMING DEVICE
2	B95400109	C-CLAMP

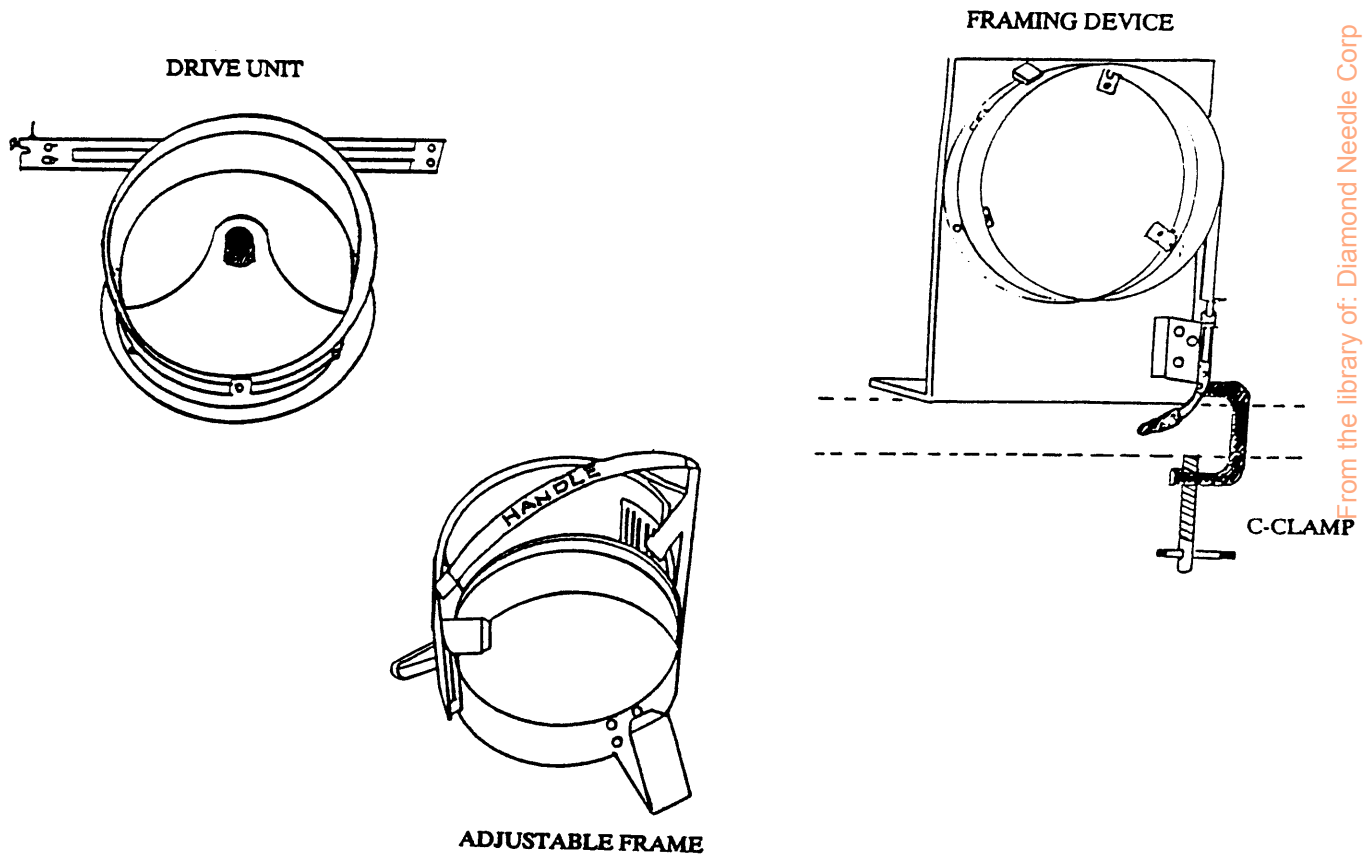

Cap Frame Kit Parts - Fig. 1

MACHINE SETUP FOR CAP FRAME:

1. REMOVE TABLE INSERT

Grasp the removable portion of the table top firmly with both hands. Pull straight out and away from the sewing head. This reveals the cylinder arm, as well as additional space needed for installation of the cap frame.

2. INSTALL RAISED THROAT PLATE

Two types of throat plates are provided with the 800XLC machine- a flat throat plate and a raised throat plate (see fig #2.) The **Flat Throat Plate** is used with all hooped and clamped garments when monogramming with the standard table top. The **Raised Throat Plate** must be used when monogramming baseball caps with the cap frame and open table top.

TO CHANGE THROAT PLATE

Step 1:

(See fig. #3) Remove the two screws securing the flat throat plate to the cylinder arm. Remove flat throat plate and put in a safe place.

Step 2:

Line up the raised throat plate over the end of the cylinder arm, insert the two screws and tighten.

Throat Plate Types - fig 2

FLAT

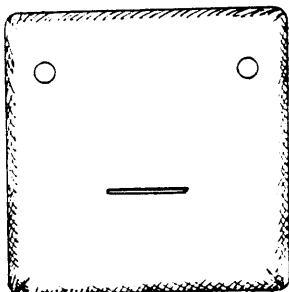

RAISED

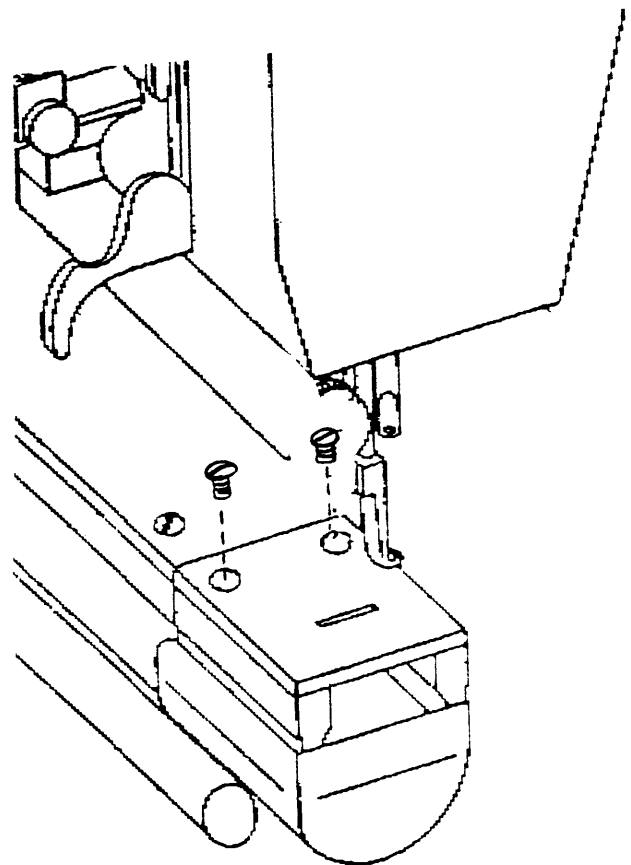
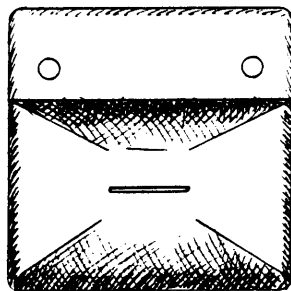

From the library of: Diamond Needle Corp

Installing Throat Plate - fig 3

3. INSTALL CAP FRAME DRIVE UNIT ONTO THE XLC

Step 1:

Attach cap frame bar (black bar) to pantograph bar with two screws provided. The screws should be left loose so the cap frame bar can be correctly lined up.

Step 2:

Slide drive unit over cylinder arm, the pivot bar should slide easily into the center shaft of drive unit (see fig. # 4)

Step 3:

If binding starts to occur remove the drive unit, line up with pivot shaft a second time and try again.

Step 4:

Once the drive unit is in position the cap frame bar must be aligned perfectly parallel with the drive unit. Use the edge of the table top as a guide (see fig. #5.)

Step 5:

When the desired position is found, tighten the two screws on the cap frame bar snugly.

Step 6:

Once parallel, tighten two black thumbscrews to secure drive unit to cap frame bar.

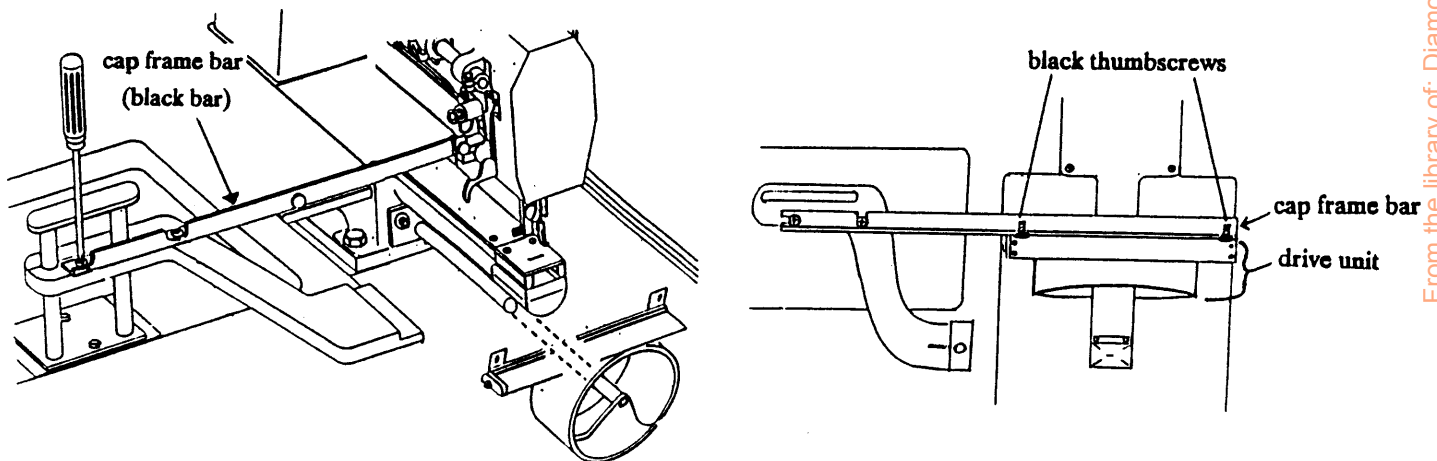

Align Cap Frame Bar - fig 5

Slide Drive Unit onto machine -
fig 4



Note:

- cap frame bar and drive unit must be parallel or binding may occur during the sewing process, causing distortion to the embroidery. Double check after extensive use of the cap frame. Realign if necessary.

4. SET THE ADJUSTABLE FRAME'S SEWING FIELD

The adjustable frame is normally shipped in its closed position- which is its smallest sewing field. To adjust the frame for your caps, follow these steps:

Step 1.

Loosen the two straight screws on either side of the adjustable frame (see fig. #6.) The slotted portion will slide open when the screws have been loosened. The maximum sewing field size is 2-1/4" x 6" when the cap frame is adjusted fully open. This allows 1/4" clearance for the presser foot.

Step 2.

Once the desired position is found tighten the 4 set screws snugly.

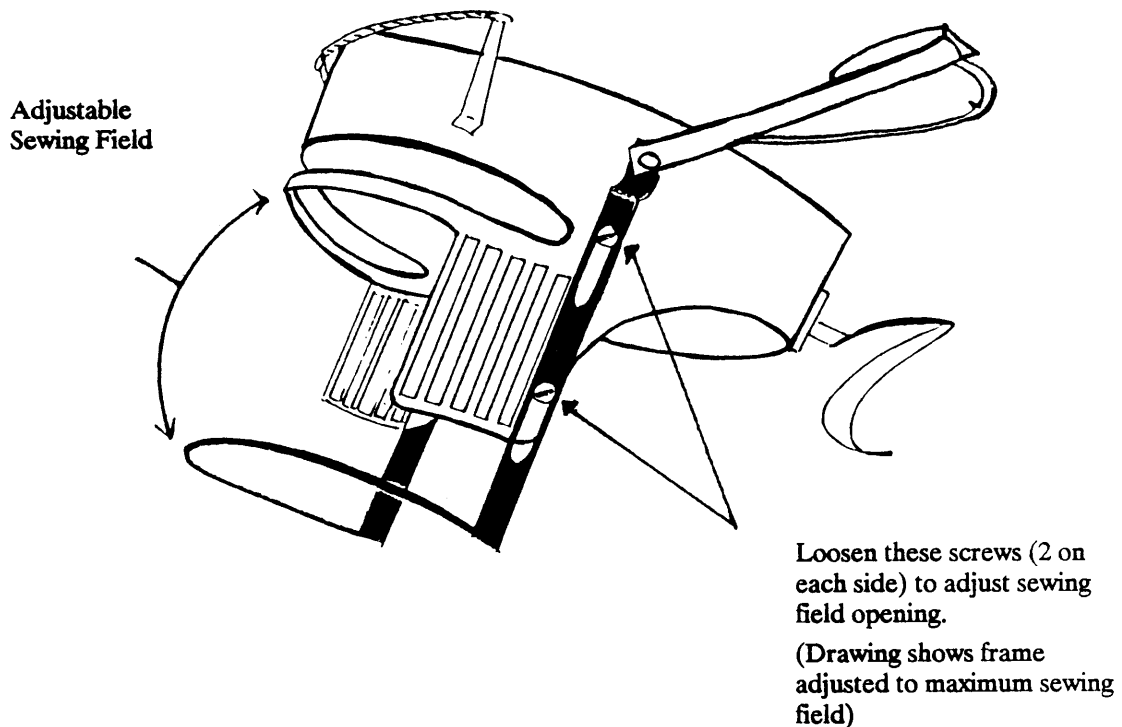

Adjusting the Sewing Field - fig 6

5. LOAD CAP ONTO FRAME

STEP 1.

The framing device should be securely fastened to a table by using the C-Clamps supplied in your kit.

STEP 2.

Located on the right hand side of the framing device is a metal lever which should be in the down position.

STEP 3.

Holding onto the red handle, secure the frame onto the framing device, by pushing firmly to lock the ball bearings into the pre-cut holes on the frame. Remember to push the metal lever up (closed) to lock in the frame.

STEP 4.

Push up and out on the red handle, to open cap frame. Hold the inner sweatband on the underside of the cap and fold outward, holding the sweatband out, slide the cap over the adjustable frame so the front of the cap is located in the center of the sewing field area. Insert the sweatband seam into the slot of the capframe. (For a center guide, align the top seam of the cap with the metal notch at the top of the handle.)

STEP 5.

Push up on the red handle and lock the bar into place.

STEP 6.

Secure the bill of the cap under the elastic strap to eliminate possible shifting.

STEP 7.

The plastic adjustable strap on the back of the cap should be secured under the silver hook located on the bottom of the adjustable frame.

STEP 8.

Pull down on the sides of the cap for a tight smooth fit. Like all monogrammed items, caps must be framed tightly.

STEP 9.

Release metal clip (down position) on the right hand side of the framing device, then pull the cap frame off the framing device by pulling on the red handle.

6. LOAD THE ADJUSTABLE FRAME ONTO DRIVE UNIT

STEP 1.

Be sure the metal lever on the drive unit is in the down position (open). Holding onto the red handle, secure the frame into the drive unit by pushing firmly to lock the ball bearings into the pre-cut holes on the frame. You should hear it lock into place.

STEP 2.

Push metal lever up into its closed and locked position. You are now ready to monogram your cap. Remember your maximum sewing field is 2 1/4" x 6". It is advisable to perimeter trace for each new program to insure a safe sewing path.

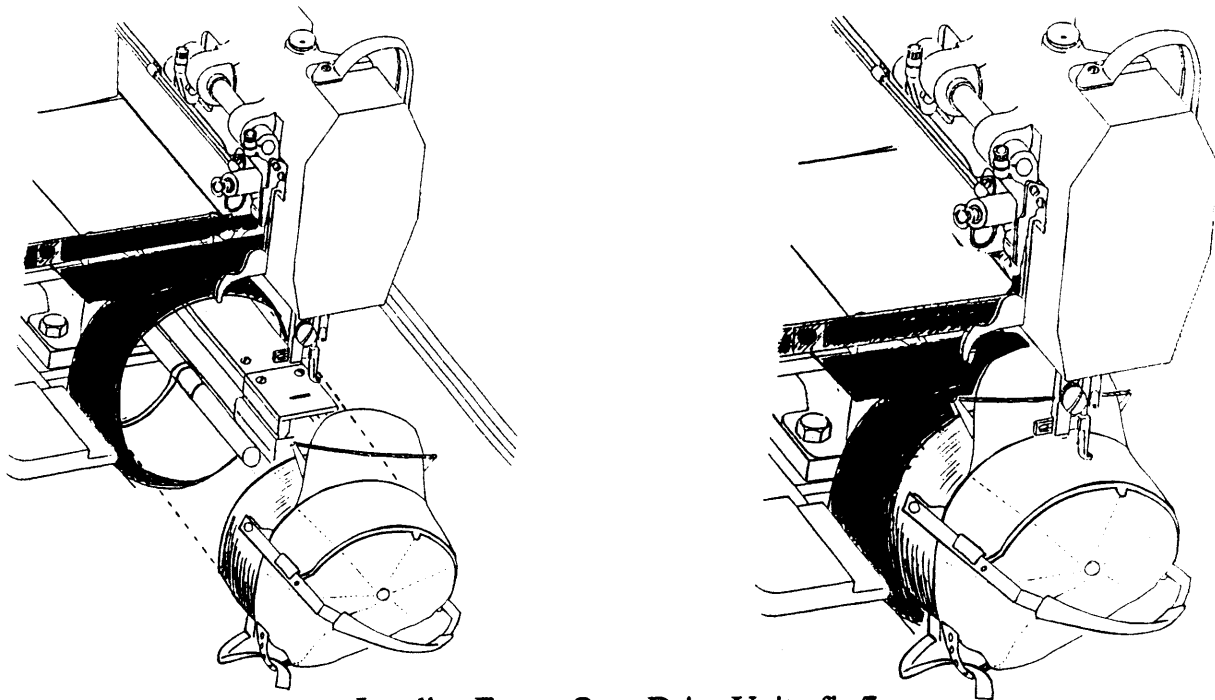

Loading Frame Onto Drive Unit - fig 7



NOTE:

- Be careful not to add too much pressure when attaching the frame, this could result in misalignment of the black frame bar. Check for needed adjustments.

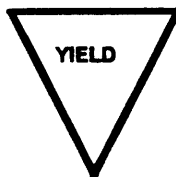

CAUTION:

- Make sure drive unit clip is in the closed and locked position (up) when machine is sewing or repositioning cap frame. Otherwise the silver clip will catch on machine frame.
- Drive unit should be disconnected from cap frame bar (black bar) when centering pantograph to avoid damage to drive unit.

7. ADJUST JUMP FOOT HEIGHT

Whenever you change fabrics, you should adjust the Jump Foot Height; installing the Raised Throat Plate makes this adjustment especially important.

Step 1

Turn the motor safety switch OFF.

Step 2

Attach the material to be monogrammed.

Step 3

Make sure the jump (presser) foot lift lever is in the down position.

Step 4

Rotate the handwheel until the presser foot reaches its lowest point of travel.

Step 5

Loosen the jump foot thumbscrew, then manually slide the jump foot up or down as required until the jump foot is lightly pressing on the fabric.

FINAL STEPS

"H" HAT MODE COMMAND

The "H" command (Hat Mode- described on page 196-A) will program the machine to sew Upside/Down/Backwards ("U") (since the caps are inserted upside/down into the machine), will set the pantograph position to the approximate center of the sewing field, and display a checklist of these hat clamp installation procedures.

PROGRAM MONOGRAM

Program your monogram as normal, but keep in mind that the sewing area is 2-1/4" by 6". Remember that Arching will add to the height of your monogram.

PREVIEW

Preview your monogram: the outline shown on the preview is for the cap frame adjusted to its largest sewing field!

PERIMETER TRACE

Make sure your monogram will fit in the cap frame sewing field: Perimeter Trace each new monogram program. If your monogram has letters that sew below the baseline (lower case j, g, p etc.) you may want to trace the sewing path too.



YIELD

CAUTION:

- Remember that the small foot gives more sewing area. If you use the large foot, leave more clearance.
- Due to mechanical differences between hat clamp frames, and the adjustments, PREVIEW and PERIMETER TRACE EACH HAT to avoid damage to your Hat Frame and Sewing head.